

PARKINSON'S DISEASE IN A LARGE TURKISH PEDIGREE
WITH SNCA DUPLICATION (PARK4):
COMPLEXIN-1 AS A POTENT BIOMARKER FOR PREDICTIVE DIAGNOSIS

by

Suna Lahut

M.S., Molecular Biology and Genetics, Boğaziçi University, 2011

Submitted to the Institute for Graduate Studies in
Science and Engineering in partial fulfillment of
the requirements for the degree of
Doctor of Philosophy

Graduate Program in Molecular Biology and Genetics
Boğaziçi University
2015

PARKINSON'S DISEASE IN A LARGE TURKISH PEDIGREE
WITH SNCA DUPLICATION (PARK4):
COMPLEXIN-1 AS A POTENT BIOMARKER FOR PREDICTIVE DIAGNOSIS

APPROVED BY:

Prof. A. Nazli Basak
(Thesis Supervisor)

Prof. Georg Auburger
(Thesis Co-advisor)

Prof. Hülya Apaydın

Prof. Kuyaş Buğra

Assoc. Prof. Tolga Emre

Prof. Uğur Özbek

DATE OF APPROVAL: 10.07.2015

To the world's cutest Parkinson's patient and
to a history Professor who always told the best stories;
to my grandfathers

ACKNOWLEDGEMENTS

I am heartily grateful to my supervisor Prof. A. Nazlı Başak and co-advisor Prof. Georg Auburger. They encouraged me with their valuable comments and continuously supported me in developing this thesis.

I would like to thank Suzana Gispert for her continuous guidance in experimental designs and explications.

I express my appreciation to Prof. Hülya Apaydın, Prof. Kuyaş Buğra, Prof. Uğur Özbek and Assoc. Prof. Tolga Emre for devoting their time to evaluate this thesis. I thank Assoc. Prof. Hülya Tireli for referring the PARK4 family to us, and Caroline Pirkevi who started to work on this family.

At this point, I would also like to acknowledge the Suna-İnan Kıraç Foundation, Boğaziçi University and Goethe University Research Funds for the financial support they provided throughout my PhD. study.

I would like to express my thanks to the present NDAL members and *the smarties* for their sincere friendship and all the happy times we spent and will spend together. Herewith, I sincerely thank Özgür Ömür who has been a very good friend, a perfect teammate, a thoughtful boyfriend and certainly will be a perfect companion for the rest of my life.

Last but not least, I owe my deepest gratitude and love to my devoted parents, adorable sister and little brother for being the best family that anyone could ever ask for...

ABSTRACT

PARKINSON'S DISEASE IN A LARGE TURKISH PEDIGREE WITH SNCA DUPLICATION (PARK4): DEVELOPING MOLECULAR BIOMARKERS FOR PREDICTIVE DIAGNOSIS

Accumulation and aggregation of alpha-synuclein (SNCA) is a hallmark of Parkinson's disease (PD). Considering the roles of SNCA in both idiopathic and familial PD, we studied blood samples from a large pedigree with SNCA duplication (PARK4), to identify effects of SNCA gain-of-function on expression levels of downstream genes as potential disease biomarkers. Downregulation of complexin-1 (CPLX1) expression level was found to be correlated with PARK4 and also the further investigated cohort with REM sleep behavior disorder (RBD), which resembles presymptomatic PD. In global RNAseq profiling of blood from presymptomatic PARK4, significant upregulations for immune system, lysosome, lipid and platelet activation pathways were detected. The representative genes of upregulated pathways, SPP1, GZMH, and PLTP, were validated in PARK4. However, unlike CPLX1, they failed to distinguish presymptomatic PD from healthy individuals. The longest size variant (allele 2) of the Rep1 repeat region of the SNCA promoter is known to be associated with PD risk. This region was analyzed in idiopathic PD and restless leg syndrome (RLS). Rep1 allele 2 frequency was found significantly decreased in RLS, suggesting reduced SNCA levels contributing to disease. The WW Domain Containing E3 Ubiquitin Protein Ligase (WWP2) mRNA expression level was tested in PARK4 and RBD and was observed to mimic SNCA expression profiles in both cohorts. Western blot analyses of double transfected cells suggested that in the presence of WWP2, SNCA-wildtype, but not SNCA-A53T-mutant, to be degraded.

ÖZET

SNCA DUPLİKASYONLU BÜYÜK BİR AİLEDE PARKİNSON HASTALIĞI (PARK4): AYIRICI TANI İÇİN BİYO-BELİRTEÇ GELİŞTİRİLMESİ

Parkinson hastalığının (PH) önemli bir işareti, hücrede alfa-sinüklein (SNCA) birikimi ve agregasyonudur. Bu tez çerçevesinde, SNCA'nın idiyopatik ve ailesel PH'deki işlevi göz önünde bulundurularak, SNCA duplikasyonlu (PARK4) büyük bir aile, hastalık biyomarkörleri geliştirmek için, model olarak kullanıldı. SNCA-toksik-işlev kazanma mekanizmasından etkilenen genlerin ifade değişimleri, olası biyomarkörler olarak incelendi. Bu genlerden kompleksin-1'in (CPLX1) ifade değişimindeki azalma anlamlı bulundu ve bir sonraki aşamada presemptomatik PH'ye benzeyen REM uyku bozukluğu hastalarında (RBD) doğrulandı. Presemptomatik PARK4 taşıyıcılarının kan örnekleri kullanılarak gerçekleştirilen tüm RNA dizi analizinde, bağışıklık sistemi, lizozomal, lipid ve platelet aktivasyon yollarında anlamlı artışlar görüldü. Bu yollarda öne çıkan SPP1, GZMH ve PLTP genlerindeki ifade artışları, PARK4'de doğrulandı. Fakat, CPLX1'in aksine bu genler presemptomatik PH'yi sağlıklı bireylerden ayıramadı. SNCA geninin promotorundaki Rep1 tekrar bölgesinin en uzun aleli olan alel 2'nin PH riski ile ilişkili olduğu bilinmektedir. Bu bölge, idiyopatik PH ve huzursuz bacak sendromu (RLS) hastalarında incelendi ve alel 2 frekansının RLS'de, PH'ye kıyasla azalmış olduğu bulundu. Bu sonuç, SNCA düzeyindeki azalmanın RLS mekanizmasına etki edebileceğine işaret etti. WW bölgesi içeren E3 übikülin protein ligaz (WWP2) mRNA ifade düzeyi PARK4 ve RBD hastalarında incelendi ve SNCA ifadesiyle doğru orantılı bulundu. Çift-transfekte hücrelerde yapılan Western blot analizinde, WWP2'nin yabancı-SNCA'yı parçaladığı, fakat A53T-mutant-SNCA'ya etki etmediği gözlemlendi.

TABLE OF CONTENTS

ACKNOWLEDGEMENTS	iv
ABSTRACT	v
ÖZET	vi
LIST OF FIGURES	x
LIST OF TABLES	xii
LIST OF ACRONYMS/ABBREVIATIONS	xiii
1. INTRODUCTION	1
1.1. Clinical Features of Parkinson’s Disease	1
1.1.1. Sleep Disorders in PD	2
1.2. Neuropathology of Parkinson’s Disease	3
1.3. Genetics of Parkinson’s Disease	6
1.3.1. Autosomal Dominant Forms of PD	7
1.3.2. Autosomal Recessive Forms of PD	7
1.3.3. Environmental Risk Factors of PD	9
1.4. SNCA in Parkinson’s Disease	10
1.4.1. The Structure and Function of α -synuclein	11
1.4.2. Toxic Gain-of-Function of α -synuclein	13
1.4.3. Potential Pathogenic Effects of α -synuclein	16
1.5. Treatment of Parkinson’s Disease and Approaches for Therapy	19
1.6. Biomarkers of Parkinson’s Disease	20
2. PURPOSE	22
3. MATERIALS	23
3.1. Subjects and Samples	23
3.2. Genotyping experiments	23
3.3. Agarose Gel Electrophoresis	27
3.4. Western Blot Analyses	28
3.5. Cell Culture experiments	30
3.6. General Lab Instruments	32
3.7. General Equipments	34
3.8. Software	35

4. METHODS	37
4.1. Blood collection	37
4.2. DNA Isolation from Blood	37
4.2.1. Agarose Gel Electrophoresis	37
4.2.2. Spectrophotometry	38
4.3. RNA Isolation	38
4.3.1. RNA Isolation from Blood	38
4.3.2. RNA Isolation from Cultured Cells	38
4.4. DNase Treatment and cDNA synthesis	38
4.5. Polymerase Chain Reaction Analyses	39
4.5.1. Genotyping Analyses	39
4.5.2. Expression Analyses	39
4.5.3. Rep1 Analyses	40
4.6. GeneScan Analysis	40
4.7. Comparative Genomic Hybridization	41
4.8. RNA Sequencing	41
4.9. Protein Isolation	42
4.9.1. Protein Isolation from Blood	42
4.9.2. Protein Isolation from cultured cells	43
4.10. Western Blot Analyses	43
4.10.1. Western Blotting for Proteins Isolated from Blood	43
4.10.2. Western Blotting for Protein Isolated from Cells	44
4.11. Cell Culture Analyses	44
4.11.1. Maintenance of HeLa Cells	44
4.11.2. Cell freezing	45
4.11.3. Cell thawing	45
4.11.4. Transfection of Cells	45
5. RESULTS	47
5.1. Genotyping of the PARK4 Family	47
5.2. Taqman Assay Selection and Normalization of the Data	48
5.3. Effect of Duplication on mRNA and Protein Expression	49
5.4. Effect of PARK4 Mutation on Candidate Biomarkers	51
5.5. Effects of Parkinson's Disease on CPLX1	55

5.6.	RNA Sequencing Analysis	58
5.7.	Validation of The Previously Reported PD Biomarkers	60
5.8.	Rep1 Analyses in German IPD and RLS cohorts	60
5.9.	Effects of WWP2 on SNCA	64
5.9.1.	WWP2 as Blood Biomarker for PD	64
5.9.2.	Transfection of HeLa Cells	65
6.	DISCUSSION	70
6.1.	Importance of The PARK4 Family	70
6.2.	CPLX1 in Parkinson's Disease	71
6.2.1.	Function of Complexins	71
6.2.2.	Possible Mechanism in PD	72
6.2.3.	CPLX1 as a PD biomarker	73
6.2.4.	CPLX1 in Human SH-SY5Y	74
6.2.5.	CPLX1 in PD Patient Brain	75
6.2.6.	CPLX1 Variants as PD Risk Factor	77
6.2.7.	Absence of CPLX1 Upregulates SNCA Levels	77
6.3.	RNA Sequencing Analyses	78
6.4.	Other Biomarkers of Parkinson's Disease	79
6.5.	Rep1 Analyses in IPD and RLS	80
6.6.	SNCA Ubiquitination by WWP2	81
7.	CONCLUSION	85
	APPENDIX A: SUPPLEMENTARY TABLES	86
	APPENDIX B: INFORMED WRITTEN CONSENT	87
	APPENDIX C: PUBLICATIONS DURING PH.D. STUDY	92
	REFERENCES	97

LIST OF FIGURES

Figure 1.1.	The original page from “A Manual of Diseases of the Nervous System”. ...	2
Figure 1.2.	Dopamine projection.	4
Figure 1.3.	Lewy body pathology beyond the substantia nigra.	5
Figure 1.4.	Spreading of LB pathology to midbrain and cortex.	6
Figure 1.5.	Schematic protein structure of SNCA.	11
Figure 1.6.	SNCA promotes SNARE-complex formation.	13
Figure 1.7.	Cytotoxic mechanisms of SNCA.	15
Figure 1.8.	Transmission mechanisms of SNCA.	18
Figure 4.1.	Representative scheme of the Comparative Genomic Hybridization.	41
Figure 4.2.	Scheme of Illumina TruSeq mRNA library preparation.	42
Figure 4.3.	Empty plasmid-DNA maps.	46
Figure 5.1.	The PARK4 family pedigree.	47
Figure 5.2.	CGH result representing two duplicated regions.	48
Figure 5.3.	Bar graphs representing three different <i>SNCA</i> Taqman assays.	49
Figure 5.4.	Bar graph demonstration of three duplicated genes.	50
Figure 5.5.	Western blot analyses representing the SNCA dimer and monomer.	51
Figure 5.6.	Expression differences of the downstream genes.	52
Figure 5.7.	Distribution of significance of the effect of SNCA duplication.	53
Figure 5.8.	ROC curve analysis of <i>CPLX1</i> , <i>YWHAE</i> , <i>YWHAB</i> and <i>YWHAG</i>	54
Figure 5.9.	mRNA expression changes of <i>CPLX1</i> , <i>YWHAE</i> and <i>YWHAB</i>	55
Figure 5.10.	Bar graphs representing the mRNA expression changes of <i>CPLX1</i> in PARK4, IPD and RBD.	56
Figure 5.11.	Demonstration of <i>Cplx1</i> mRNA downregulation in mice.	57
Figure 5.12.	Scatter plots representing the mRNA expression levels.	59
Figure 5.13.	Scatter plots representing the mRNA expression levels of the previously reported PD biomarkers HNF4A and PTBP1.	60
Figure 5.14.	PCR amplification of Rep1 region.	61
Figure 5.15.	Representative genescan results of Rep1 genotypes.	61
Figure 5.16.	Allele frequency of Rep1 size is shown in percentage.	63

Figure 5.17. WWP2 mRNA expression levels in comparison to SNCA mRNA levels in PARK4 and RBD cohorts.	64
Figure 5.18. WWP2 mRNA expression levels in comparison to SNCA mRNA levels in SNCA-nrml and SNCA-elvd subgroups of RBD individuals.	65
Figure 5.19. mRNA expression levels of WWP2 and SNCA in single and double transfected HeLa cells.	67
Figure 5.20. WB results of the transfected cells.	68
Figure 5.21. Summary of methods and results.	69
Figure 6.1. Models of complexin structure and function.	73
Figure 6.2. CPLX1 changes in protein and mRNA levels of transiently transfected human SH-SY5Y cells.	75
Figure 6.3. PD midbrain autopsies with CPLX1 cytoplasmic and neuritic aggregates.	76
Figure 6.4. Elevated SNCA mRNA and protein levels in Cplx1 knock-out mice.	78
Figure 6.5. Electron microscopy of blood platelets after stimulus-triggered degranulation.	80
Figure 6.6. KEGG pathway map of ubiquitin mediated proteolysis.	83

LIST OF TABLES

Table 1.1.	Genes associated with the monogenic forms of Parkinson disease.	8
Table 3.1.	List of primers and probes used for PARK4 genotyping.	23
Table 3.2.	TaqMan gene expression assays.	24
Table 3.3.	List of materials used in DNA and RNA experiments.	26
Table 3.4.	Materials used in agarose gel electrophoresis.	27
Table 3.5.	Specifications of the antibodies used.	28
Table 3.6.	Materials used in protein experiments.	28
Table 3.7.	Ingredients of media used in cell culture experiments and related buffers.	30
Table 3.8.	Plasmid and their inserted genes.	31
Table 3.9.	Plasmid preparation and transfection materials.	32
Table 3.10.	General laboratory instruments.	32
Table 3.11.	General laboratory equipments.	34
Table 3.12.	Software and appliers.	36
Table 4.1.	Representative $2^{-\Delta\Delta Ct}$ equation for PARK4 subjects and controls.	39
Table 4.2.	Calculating fold changes of the proteins in WB analyses.	44
Table 5.1.	SNCA transcription changes calculated within each blood cell type.	50
Table 5.2.	Genotype matrices for RLS patients and CNTs.	63
Table 5.3.	List of plasmids used for single and double transfections and their abbreviations used in result figures.	66
Table 6.1.	CPLX1 SNP rs1794536 G-allele is associated with PD risk.	77
Table S1.	The upregulated pathways in PARK4.	86

LIST OF ACRONYMS/ABBREVIATIONS

4q	Long Arm of Chromosome 4
A	Adenine
AD	Autosomal Dominant
APS	Ammonium Persulfate
AR	Autosomal Recessive
ATP	Adenosine Triphosphate
ATP13A	ATPase Type 13A1
ATXN3	Ataxin 3
BCA	Bicinchoninic Acid Assay
bp	Base Pair
BSA	Bovine Serum Albumine
C	Cytosine
CaCl	Calcium Chloride
cDNA	Complementary DNA
CGH	Comparative Genomic Hybridization
cm ²	Centimetre Square
CNS	Central Nervous System
CNT	Control
CO ₂	Carbondioxide
CPLX1	Complexin-1
Ct	Cycle treshold
dH ₂ O	Distilled water
DJ-1	Parkinson protein 7
DMSO	Dimethyl sulfoxide
DNA	Deoxyribonucleic acid
dNTP	Deoxyribonucleotide Triphosphate
E1	Ubiquitin-activating Enzyme
E2	Ubiquitin-conjugating Enzyme
E3	Ubiquitin Protein Ligase

EDTA	Ethylenediaminetetraacetate
EtBr	Ethidium Bromide
EtOH	Ethanol
Fam	Carboxyfluorescein
FBS	Fetal Bovine Serum
FBX07	F Box Protein 7
G	Guanine
GBA	Glucosidase Beta Acid
GIGYF2	Grb10-Interacting GYF Protein-2
GSEA	Gene Set Enrichment Analyses
GZMH	Granzyme H
HCl	Hydrochloric Acid
HNF4A	Hepatocyte Nuclear Factor 4, Alpha
HTRA2	High Temperature Requirement Protein A2
kb	Kilo Base
kDa	Kilo Dalton
L-Dopa	Levodopa
LB	Lewy Body
LN	Lewy Neurite
LRRK2	Leucine-Rich Repeat Kinase 2
mA	Miliampere
Mb	Mega base
MEM	Modified Eagle Medium
mg	Miligram
MgCl ₂	Magnesium Chloride
min	Minute
ml	Mililiter
mRNA	Messenger RNA
NAC	Non-amyloid Component
NaCl	Sodium Chloride
NEAA	Non-essential Amino Acid
ng	Nanogram
°C	Centigrade Degree

OD	Optical Density
PARK1	Point Mutations in Alpha-synuclein Gene
PARK2	Parkin RBR E3 Ubiquitin Protein Ligase
PARK4	Multiplications in Alpha-synuclein Gene
PBS	Phosphate Buffered Saline
PCR	Polymerase Chain Reaction
PD	Parkinson's Disease
PH	Pleckstrin Homology Domain
PINK1	Phosphatase and Tensin Homologue-Induced Kinase 1
PLA2G6	Phospholipase A2, Group VI
PLTP	Phospholipid Transfer Protein
pmole	Picomole
PTBP1	Polypyrimidine Tract Binding Protein 1
PVDF	polyvinylidene fluoride
qRT-PCR	Real-time Polymerase Chain Reaction
RBD	REM behavior sleep disorder
REM	Rapid eye movement
RIPA	Radio Immunoprecipitation Assay
RLS	Restless Leg Syndrome
RNA	Ribonucleic Acid
ROC	Receiver Operating Characteristics
ROS	Reactive Oxygen Species
rpm	Revolutions per Minute
rs	Reference Sequence
RT-PCR	Reverse Transcriptase Polymerase Chain Reaction
SDS	Sodium Dodecyl Sulfate
sec	Second
SNc	Substantia Nigra Pars Compacta
SNCA	Alpha-synuclein
SNCA-elvd	Alpha-synuclein Elevated Levels
SNCA-nrml	Alpha-synuclein Normal Levels
SNCB	Beta-synuclein
SNP	Single Nucleotide Polymorphism

SNr	Substantia Nigra Pars Reticulata
SPP1	Osteopontin
ST13	Suppression Of Tumorigenicity 13
T	Timine
Taq	Thermus Aquaticus
TBE	Tris-Boric acid-EDTA
TBST	Tris Buffered Saline Tween
TBP	TATA Box Binding Protein
TE	Tris-EDTA
TEMED	Tetramethylethylenediamine
TWEEN	Polysorbate
UCHL1	Ubiquitin Carboxy-terminal Hydrolase L1
UTR	Untranslated Region
UV	Ultra Violet
V	Volt
VIC	4,7,2-trichloro-7-phenyl-6-carboxyfluorescein-labeled RNase P probe
VTA	Ventral Tegment Area
WB	Western Blot
WT	Wild-Type
WWP2	The WW Domain Containing E3 Ubiquitin Protein Ligase
x g	Times Gravity
YWHAB	14-3-3 Family Protein Beta
YWHAE	14-3-3 Family Protein Epsilon
YWHAG	14-3-3 Family Protein Gamma
α	Alpa
β	Beta
γ	Gamma
Δ	Delta
μg	Microgram
μl	Microliter
μM	Micromolar

1. INTRODUCTION

Parkinson's disease (PD) is the second most common neurodegenerative disorder after Alzheimer's disease, affecting 0.5-1 % of the population over 65 years, and 3-4 % in those over the age 80 (Nussbaum and Ellis, 2003). It was first described in 1817 by James Parkinson, however his study was ignored until 1877, when the famous French neurologist, Jean Martin Charcot recognized the value of his work and named the disorder after his name as "Parkinson's disease" (Parent and Parent, 2010).

1.1. Clinical Features of Parkinson's Disease

PD is the most significant category of parkinsonism, which is a syndrome by the combination of six motoric clinical features: tremor, bradykinesia, rigidity, loss of reflexes, flexed posture and the so-called freezing phenomenon, where the feet are instantly "glued to the floor". Presence of at least two of the above symptoms, one of them being tremor or bradykinesia is essential for the diagnosis of parkinsonism. The criteria that help to distinguish PD from parkinsonism are (i) asymmetrical onset of symptoms beginning on one side of the body, (ii) presence of *resting* tremor, and not *essential* tremor, which is not present at rest and increases amplitude with activity of the arm, (iii) significant clinical response to dopamine precursor drugs. The mostly recognized PD symptom, resting tremor is generally the first symptom that appears in patients. Despite its recognition in PD, it also may never develop in some cases. The motoric symptoms of PD being resting tremor, bradykinesia and rigidity, are associated with progressive loss of dopamine levels, so they respond to dopamine precursor drugs, however, PD symptoms deteriorate over time, and the bradykinesia that responded to drug in the early stages, no longer benefits from the medication. Moreover, as the disease progresses, postural abnormalities develop due to non-dopaminergic lesion pathology, thus, postural symptoms respond insufficiently to dopaminergic medication, too (Figure 1.1) (Fahn, 2003).

The motoric clinical features of PD are frequently accompanied by non-motor symptoms at early stages, such as depression, olfactory dysfunction, anxiety and sleep

disorders (Berg *et al.*, 2012). However, none of these early non-motor symptoms are useful for a definite PD diagnosis. At more advanced stages of PD, impairments in cognitive functions are frequent. Around 20 % of PD patients further develop dementia and a less severe cognitive impairment is recognized in early stages of these patients (Owen, 2004).

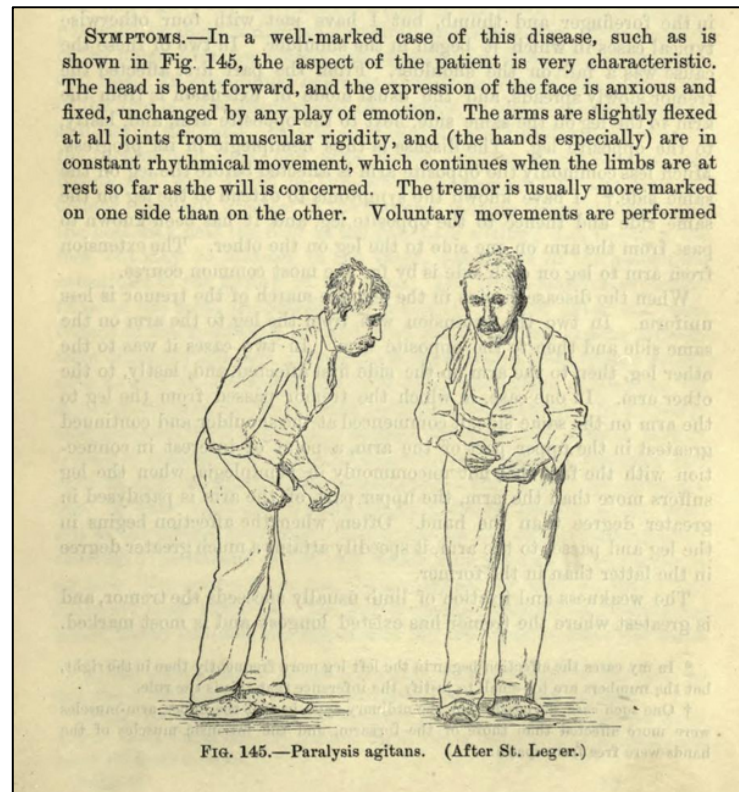

Figure 1.1. The original page from “A Manual of Diseases of the Nervous System”; a patient suffering from Parkinson’s disease with the typical flexed posture (Gowers, 1886, p.591.).

1.1.1. Sleep Disorders in PD

Sleep disorders in PD patients are very common; insomnia, daytime sleepiness with sleep attacks, restless-legs syndrome and rapid eye movement-sleep behavior disorder are the most frequent sleep disorders in PD (Schrempf *et al.*, 2014).

Restless leg syndrome (RLS) is a sleep-related movement disorder that has five diagnostic criteria introduced by the International RLS Study Group: (i) An urge to move

the legs at rest and an unpleasant feeling in the legs, (ii) partial or total relieve by movement of the leg, (iii) worsening of the unpleasant feeling during periods of rest or inactivity, (iv) occurrence or worsening of this feeling in the evening or night, rather than during the day and (v) lack of another medical or behavioral condition that could lead to the above symptoms (e.g., leg edema, arthritis, leg cramps, positional discomfort) (Allen *et al.*, 2003). RLS is also due to a dopaminergic dysfunction like PD, thus they have the same effective treatment with dopaminergic drugs. However, there is no evidence for a common genetic or pathophysiological background for RLS and PD, yet. Although many studies have reported association of these two diseases, reliable data about the prevalence of RLS in PD patients is missing (Schrempf *et al.*, 2014).

Rapid eye movement (REM)-sleep behavior disorder, abbreviated as RBD, is characterized by the loss of normal muscle atonia and performing behaviors like laughing, talking, shouting and exhibiting movements, such as kicking and boxing during rapid eye movement sleep. RBD diagnosis requires recurrent complex behavior or vocalizations together with a REM-sleep without atonia. RBD is a very good clinical predictor of PD, since more than 80 % of RBD cases later in their lives develop PD, whereas other early non-motor clinical features of PD are far less specific (Schrempf *et al.*, 2014). All these features make RBD a very important subject for studying early stages of PD and to identify biomarkers

1.2. Neuropathology of Parkinson's Disease

Dopamine is one of the major neurotransmitters in the brain. Dopamine projection originates from one of two adjacent sub-regions of the ventral mesencephalon: the substantia nigra and the ventral tegmental area (VTA) (Figure 1.2). Each pathway has a different set of functions and is consequentially involved in distinct neuropathologies (Lin and Rosenthal, 2003). PD is generally defined as a movement disorder associated with the severe degeneration of neurons in the nigro-striatal system. Loss of nigro-striatal dopaminergic neurons in the substantia nigra terminates dopamine projection to the striatum leading to the motor symptoms. It has been estimated that the PD motor symptoms start after dopamine levels in the striatum are already reduced to 60-70 % of the

normal level. The amount of dopaminergic cell death is strongly correlated with the severity of the motor symptoms of PD (Schapira, 2006). Besides the degeneration of dopaminergic neurons, the serotonergic and noradrenergic systems are also affected leading to the non-motor symptoms of PD (Braak *et al.*, 2003).

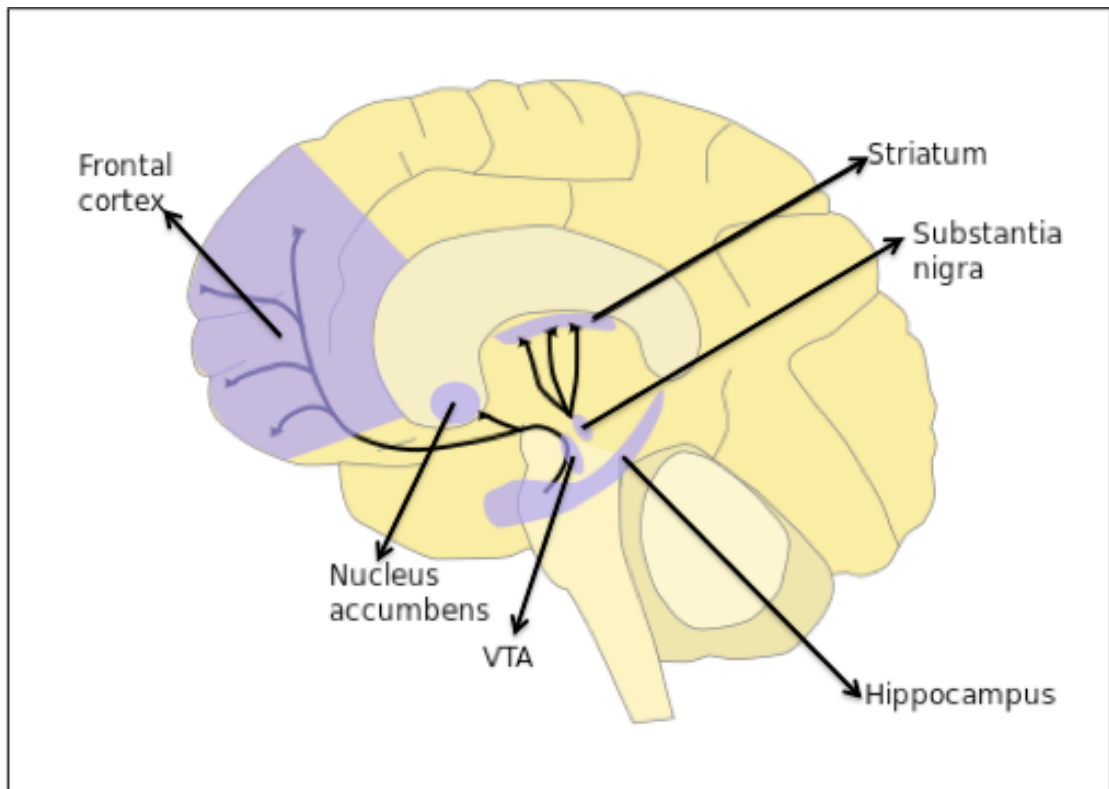

Figure 1.2. Dopamine projection, represented by black arrows, from nerve cell bodies located in the ventral tegmental area (VTA) to the nucleus accumbens and the prefrontal cortex, and from substantia nigra to the striatum.

Post mortem analyses of PD patients show intracellular aggregates in the surviving neurons not only in substantia nigra but also in other vulnerable regions that are the Lewy bodies (LBs) and Lewy neurites (LNs), depending on their localization in the cell body or in the outgrowths, respectively (Figure 1.3) (Kingsbury *et al.*, 2010). It is still a matter of debate if the Lewy body pathology is toxic to the cell and causes death, or if it is a protective formation (Sian-Hulsmann *et al.*, 2015).

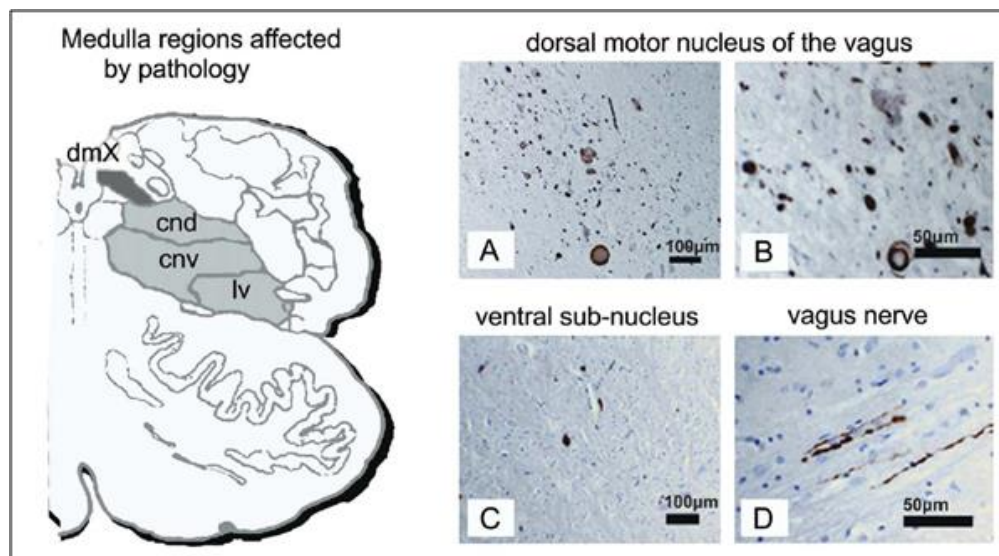

Figure 1.3. Lewy body pathology beyond the substantia nigra: in the affected medulla regions; in dorsal medulla (A & B), throughout the central nucleus (C) and in exiting nerves (D) (Kingsbury *et al.*, 2010).

According to Braak hypothesis, neuropathology starts in extra-nigral or even extra-central nervous system structures and then spreads to intact areas of the brain. LB pathology first starts at the olfactory bulb and the anterior olfactory nucleus or at the enteric nervous system, possibly in the gastrointestinal tract. In the middle stage of the disease LBs spread into the dopaminergic neurons of the substantia nigra; and the neocortex is affected only in the late stage of the disease. This precise order is not always valid, but increases the likelihood that LBs and neurodegeneration spread to intact areas in a prion-like way. Prions are infectious proteins, which do not contain nucleic acids and cause diseases because they form toxic aggregates and filaments by misfolding in β -sheet-rich conformation. The systematic spread of Lewy body pathology, might be caused by external pathogens that enter the body through the gastrointestinal tract and trigger pathological aggregation and then proceed to the brain through the glossopharyngeal and vagus nerves (Figure 1.4) (Braak *et al.*, 2003).

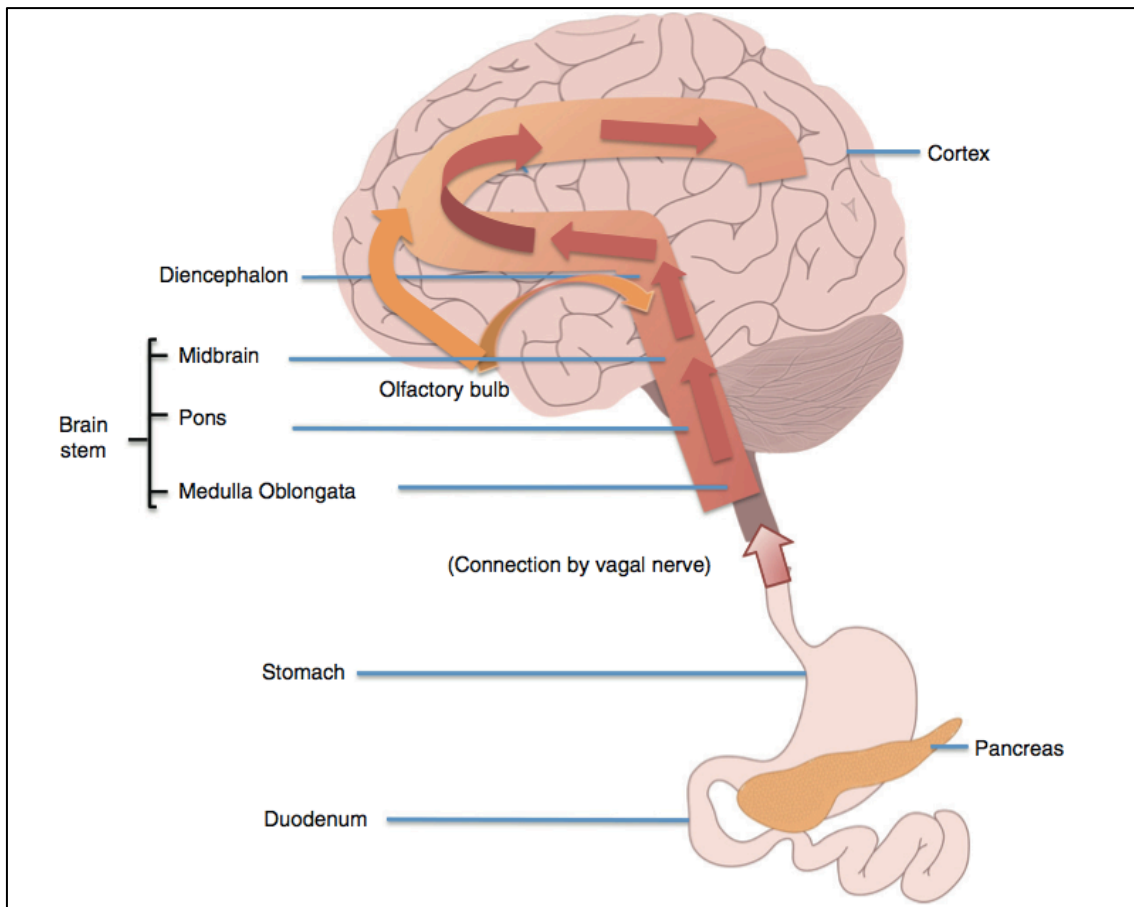

Figure 1.4. Spreading of LB pathology to midbrain and cortex from the olfactory bulb (orange arrows) and the gastrointestinal tract (red arrows) (Hansen and Li, 2012).

1.3. Genetics of Parkinson's Disease

Parkinson's disease was presumed to be a non-genetic disorder caused by environmental factors until Polymeropoulos et al identified the A53T mutation in the α -synuclein (*SNCA*) gene in a large Italian family with autosomal-dominant PD (Polymeropoulos *et al.*, 1997). Over the following years, considerable progress was achieved in identification of new disease-causing genes and associating common variants that affect PD risk. Currently, PD is considered as a multifactorial disease with several genetic and environmental factors. A current list of genes, associated with PD so far, is given in Table 1., however, only eight of them (PARK1 and 4, 2, 6, 7, 8, 9, 14 and 15) give rise to the confirmed monogenic forms of PD (Table 1.1) (Gasser *et al.*, 2011).

1.3.1. Autosomal Dominant Forms of PD

There are two confirmed genes that lead to autosomal dominant (AD) forms of PD. Alterations in the first gene, *SNCA*, include six point mutations (A53T, A30P, E54K, H50Q, G51D, A53E, known as PARK1) and duplications or triplications (PARK4) (Pasanen *et al.*, 2014). Duplications account for approximately 1-2 % of AD-PD families, whereas triplications and point mutations are rarely seen. Patients with *SNCA* duplications often display classical PD phenotype. On the other hand, triplication carriers often have an earlier age of onset and a more severe phenotype, bringing to mind a direct link between the *SNCA* dosage and disease severity (Ibanez *et al.*, 2009). Only very recently four additional mutations have been identified: The H50Q mutation, that has been confirmed in two additional studies (Appel-Cresswell *et al.*, 2013, Ghosh *et al.*, 2013, Khalaf *et al.*, 2014, Proukakis *et al.*, 2013), the two mutations A18T and A29S that have been identified in a single patient (Hoffman-Zacharska *et al.*, 2013), as well as the A53E mutation that has been identified in a Finnish patient as well as in two other relatives, all showing severe PD symptoms (Pasanen *et al.*, 2014).

The most common causes of AD-PD are the mutations in *leucine-rich repeat kinase 2 (LRRK2)*. Despite the large number of variations identified in this gene, only six can be considered as definitely disease-causing (R1441G, R1441C, N1437H, Y1699C, G2019S and I2020T), explaining approximately 10 % of the AD-PD families (Di Fonzo *et al.*, 2006). Clinical characteristics of *LRRK2* mutation carriers are quite similar, if not identical, to classical PD (Healy *et al.*, 2008). An incomplete penetrance is estimated for some mutations in *LRRK2*, so it can be detected both in familial and idiopathic (sporadic) PD patients, together with the mutation-positive individuals without any symptoms (Bonifati, 2007).

1.3.2. Autosomal Recessive Forms of PD

Autosomal recessive (AR) PD is generally caused by genomic rearrangements or point mutations, seen in homozygous or compound heterozygous form, in the following three genes; *parkin (PRKN)*, *PTEN-induced putative kinase 1 (PINK1)* and *parkinson*

protein 7 (DJ-1). Mutations in the *PRKN* gene are the most common cause of AR-PD, explaining almost 50 % of recessive PD families. *PRKN* neuropathology is not always associated with LBs in the brain, this may be due to the pathogenetic difference between the AD and AR forms of PD (Hattori *et al.*, 2000). The less commonly seen *PINK1* and *DJ-1* mutations account for up to 1-8 % and 1-2 % of idiopathic PD cases, respectively (Djarmati *et al.*, 2004, Kumazawa *et al.*, 2008). LB pathology was reported only once in a patient with *PINK1* mutation, however, the neuropathology for DJ-1 remains unknown (Samaranch *et al.*, 2010).

Apart from *PRKN*, *PINK1* and *DJ-1*, another set of genes; *ATP13A2*, *PLA2G6* and *FBXO7* rarely cause atypical forms of recessive PD, with an average age of onset below 30 years and lack of LB pathology (Singleton *et al.*, 2013).

Table 1.1. Genes associated with the monogenic forms of Parkinson disease
(adopted from Verstraeten *et al.*, 2015).

Locus	Gene	Inheritance	Function	Pathological brain accumulation
PARK1/PARK4	<i>SNCA</i> *	AD	Synaptic protein	Synucleinopathy
PARK2	<i>PRKN</i> *	AR	Ubiquitin-protein ligase	Synucleinopathy (occasionally)
PARK3	<i>SPR</i>	AD	Unknown	Unknown
PARK5	<i>UCHL1</i>	AD?	Hydrolyze small C-terminal adducts of ubiquitin	Unknown
PARK6	<i>PINK1</i> *	AR	Mitochondrial Kinase	Synucleinopathy (occasionally)
PARK7	<i>DJ-1</i> *	AR	Oxidative stress protection	Unknown
PARK8	<i>LRRK2</i> *	AD	Protein phosphorylation	Synucleinopathy/tauopathy/TDP-43
PARK9	<i>ATP13A2</i> *	AR	Lysosomal protein	Iron
PARK11	<i>GIGYF2</i>	AD	Unknown	Unknown
PARK13	<i>HTRA2</i>	AD?	Serine protease	unknown
PARK14	<i>PLA2G6</i> *	AR	Phospholipid remodeling	Iron
PARK15	<i>FBXO7</i> *	AR	Phosphorylation dependent ubiquitination	Unknown

Table 1.1. Genes associated with the monogenic forms of Parkinson disease
(adopted from Verstraeten *et al.*, 2015) (cont.).

Locus	Gene	Inheritance	Function	Pathological brain accumulation
PARK17	<i>VPS35</i>	AD	Transmembrane protein trafficking	Unknown
PARK17	<i>VPS35</i>	AD	Transmembrane protein trafficking	Unknown
PARK18	<i>EIF4G1</i>	AD	eukaryotic translation initiation factor	Synucleinopathy/ tauopathy/A β
PARK19	<i>DNAJC6</i>	AR	Uncoating of clathrin-coated vesicles	Unknown
PARK20	<i>SYNJ1</i>	AR	Clathrin-mediated endocytosis	Unknown
-	<i>GBA</i>	AD?	Lysosomal hydrolyzing glucosylceramide	Unknown
-	<i>ATP6AP2</i>	X-linked	Renin and prorenin cellular receptor	Tauopathy
-	<i>COQ2</i>	AR	Coenzyme Q biosynthesis	Synucleinopathy
-	<i>DNAJC13</i>	AD	Endosomal protein sorting	Synucleinopathy

* Confirmed genes of PD. AD: autosomal dominant; AR: autosomal recessive.

1.3.3. Environmental Risk Factors of PD

Despite the progress in identifying genes, the majority of PD patients develop the idiopathic form of the disease without any known genetic modification. The major risk factor for developing idiopathic PD appears to be ageing, as in other neurodegenerative diseases like Alzheimer's disease and Amyotrophic Lateral Sclerosis. The mechanism how ageing contributes to PD is yet to be unraveled. Some other risk factors with limited supportive evidence, that have minor effects, are exposure to a herbicide (paraquat) and urate in blood, usage of nonsteroidal anti-inflammatory drugs, traumatic brain injury, and exercise. Some protective effects of tobacco and coffee have also been reported, however, the underlying protective mechanism is not understood, yet (Kiebertz and Wunderle, 2013).

1.4. SNCA in Parkinson's Disease

All neurodegenerative conditions that develop abnormal inclusion bodies immunoreactive to SNCA in neurons or glial cells are termed as synucleinopathies. PD is also considered as a multi-systemic synucleinopathy of the human nervous system. Thus, SNCA is of great importance for PD, not only because of the genetic defects leading to the disease, but also for the realization that the SNCA protein is a core component of the LBs and LNs regardless of genetic mutations (Singleton *et al.*, 2013). A specific modification of SNCA in the LBs is a single phosphorylation at the serine 129 position. This post-translational modification is mainly present in SNCA aggregated in the LBs, however, its correlation with the protein aggregation (but not degradation) is still unclear (Sato *et al.*, 2011).

Following the first report of an *SNCA* point mutation (A53T) in an extended Italian AD-PD family, five more mutations (A30P, E54K, H50Q, G51D, A53E) were associated with PD. The three best studied SNCA mutations (A53T, A30P and E54K) are known to cause protein aggregation in cell culture experiments (Pasanen *et al.*, 2014). Subsequent studies that linked SNCA to PD identified triplications and duplications of the gene. Interestingly, a gene dosage effect was apparent such that the triplication cases exhibited a more severe course with an earlier onset for PD (Fuchs *et al.*, 2007). Further, looking at the same gene in the idiopathic disease, the Rep1 polymorphic region 10 kB upstream of the SNCA transcriptional initiation site and some single nucleotide polymorphisms (SNPs) in the 3'-untranslated region are identified as genetic risk factors for idiopathic PD (Angot *et al.*, 2012, Maraganore *et al.*, 2006). All this information suggests that SNCA is heavily implicated in the pathogenesis of both familial and idiopathic PD.

Histopathological sections of PD patients revealed three major insights for the α -synuclein pathology: This pathology (i) is not limited to the cell soma, but also obvious in neuritic processes, (ii) is available in various brain regions, (iii) is present in a number of other synucleinopathies, such as Alzheimer's disease. The distribution of the pathology varies in each disease in terms of cellular and regional levels (Stefanis, 2012).

1.4.1. The Structure and Function of α -synuclein

The SNCA gene encodes for a 14.5 kDa and 140 amino acid protein, which is highly conserved in vertebrates. It is an acidic protein, ubiquitously expressed in several regions of the brain (one per cent of the total cytosolic proteins). SNCA is mainly enriched in presynaptic nerve terminals with the major localization very close to the synaptic vesicles (Kahle, 2008). SNCA lacks a defined secondary structure and is natively unfolded, however, it does form α -helical structures when binding to negatively charged lipids, or β -sheets when incubated for long periods. It is composed of three regions (Figure 1.5): (i) the amphipathic amino terminus contains hexamer repeats similar to apolipoproteins, and is responsible for membrane interactions. This region is essential for forming α -helical structures. (ii) the central hydrophobic region (NAC) confers the β -sheet secondary structure potential and (iii) a highly negatively charged carboxyl terminus prone to be unstructured. The serine amino acid at position 129 in this region is found to be phosphorylated specifically in LBs (Gallegos *et al.*, 2015).

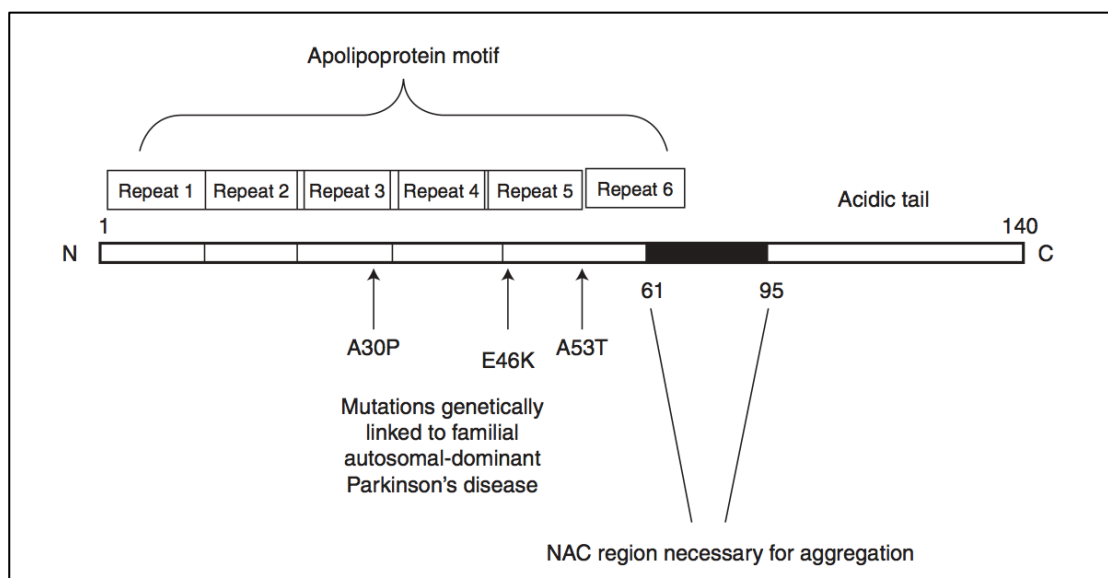

Figure 1.5. Schematic protein structure of SNCA containing the apolipoprotein motif, the NAC region and the unstructured acidic tail. (Stefanis, 2012). The H50Q, G51D, A53E mutations at repeat 5 region are not represented in this scheme.

Alpha-synuclein is a member of the synuclein protein family, consisting of α -, β - and γ -synucleins. All members are predominantly neuronal proteins. β -synuclein (SNCB) also exhibits a presynaptic localization and generally co-localizes with SNCA. On the other hand, γ -synuclein is expressed in the glial cells and in specific neuronal populations (Bendor *et al.*, 2013). What structurally differs SNCA from the other members is the presence of a NAC region, which is necessary for aggregation of the protein (George, 2002). Although SNCA belongs to the natively unstructured protein family, conformational plasticity of the protein provides a wide range of dynamic structures, thus functions depending on the environment and the binding partners (Jain *et al.*, 2013). Although the precise physiological function of SNCA is uncertain due to the outnumbering conflicting studies, the best studied and the most referred function is the control of synaptic membrane processes (Bellucci *et al.*, 2012).

Presynaptic nerve terminals release neurotransmitters by synaptic vesicle exocytosis. Synaptic exocytosis, like any other intracellular membrane trafficking system, is enhanced by a machinery that includes complexes formed by the SNARE (soluble NSF-attachment protein receptor) proteins. SNARE proteins, share a characteristic SNARE motif sequence and function in membrane fusion of the vesicles by cycling into complexes that fuel fusion, and disassembly of the complexes that makes SNARE proteins available again for another round of fusion. Continuous folding and unfolding reactions of the synaptic SNARE proteins in each fusion cycle, creates a great potential for misfolding that is counteracted by SNARE protein chaperones. Thomas C. Südhof (Nobel Prize in Physiology or Medicine, 2013), who discovered the machinery regulating vesicle trafficking and transport system, describes SNCA to promote SNARE-complex assembly in presynaptic nerve terminals through binding to phospholipids via its amino terminus and to synaptobrevin (a SNARE protein) via its carboxyl terminus (Figure 1.6). Through this binding SNCA acts as the chaperone protein for synaptobrevin leading its proper folding for SNARE-complex formation (Sudhof and Rizo, 2011). Fluorescently labeled α -synuclein in the presynaptic terminals was shown to move away from the vesicles on neuronal firing and then gradually return (Fortin *et al.*, 2005). This effect also suggests a transient binding of α -synuclein to the vesicles. Therefore, the main function of α -synuclein appears to be the control of neurotransmitter release, through effects on the SNARE complex.

Interestingly, SNCA expression is reported to be very abundant, for unclear reasons, in erythrocytes, leukocytes and platelets. More than 99 % of the SNCA resides in the red blood cells with less than 1 % of the total detected in the plasma, platelets and peripheral blood mononuclear cells. SNCA in platelets is known to be loosely associated with the membrane of the secretory alpha-granules (granules containing several growth factors) and reported to function as a specific negative regulator of alpha-granule release (Barbour *et al.*, 2008, Park *et al.*, 2002, Shin *et al.*, 2000). These findings implicate that SNCA function may not be restricted to the neurons.

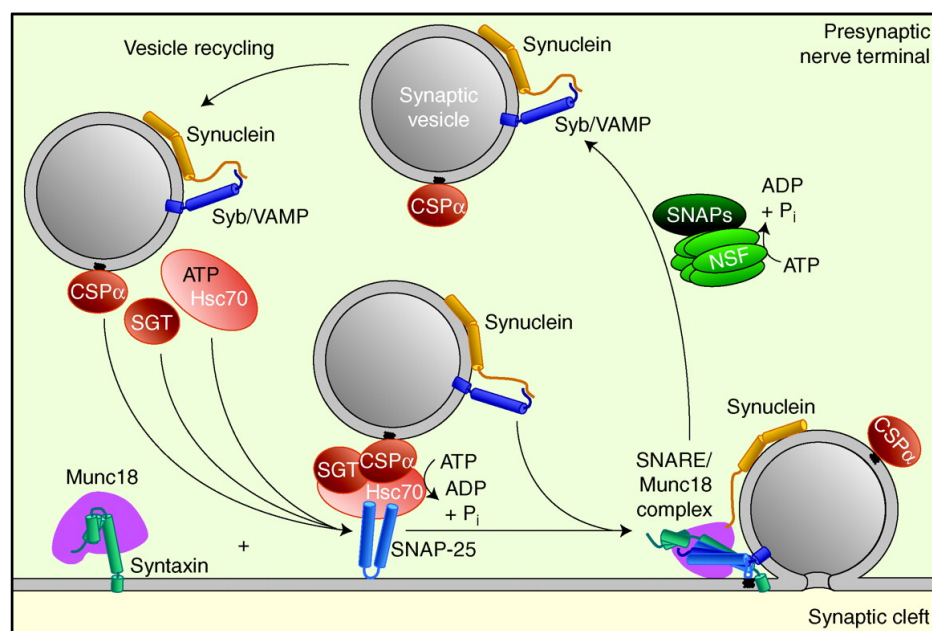

Figure 1.6. SNCA promotes SNARE-complex formation. SNARE chaperones implicated in neurodegeneration are CSP α , Hsc70, and SGT (red shapes), and α -, β -, γ -synucleins (yellow shapes). SNAP-25, Syntaxin and synaptobrevin are SNARE proteins (Sudhof and Rizo, 2011).

1.4.2. Toxic Gain-of-Function of α -synuclein

SNCA is believed to lead to PD through a toxic gain-of-function mechanism that is likely caused by the normal protein itself, when expressed above a certain level. This theory arises not only from the dosage effect of PARK4 mutations on PD phenotype, but also from the fact that only the transgenic overexpressing mice and not the *SNCA* knock-

out mice, display a clear neuropathological or behavioral phenotype (Abeliovich *et al.*, 2000, Cabin *et al.*, 2002). One of the toxic functions that SNCA gains is suggested to be leading to impaired synaptic vesicle release and synaptic failure over time, through its excess binding to the SNARE protein synaptobrevin (Sudhof and Rizo, 2011). SNCA-induced neurotoxicity in cell culture and *in vivo* models based on overexpression of the protein, has identified synaptic effects like loss of presynaptic proteins, decrease of neurotransmitter release, redistribution of SNARE proteins, enlargement of synaptic vesicles and inhibition of synaptic vesicle recycling (Stefanis, 2012). The loss of function of the protein may be rescued by the substitute synaptic function of α - and β -synuclein proteins. This conclusion arises from the finding that *SNCA* knock-out mice are viable without any defect in the synapse formation or the cell survival. However, the α -/ β -synuclein double knock-out mice show a significant reduction in the dopamine level projected to striatum (Chandra *et al.*, 2004). The toxic gain-of-function properties of SNCA may lie in its conformational flexibility, which changes upon interaction with different biological membranes and other protein complexes (Lashuel *et al.*, 2013, Plotegher *et al.*, 2014).

Accumulation of SNCA, formation of oligomers and sequestration of physiological protein in inclusions are important indicators of PD phenotype and can cause neuronal and synaptic damage (Lashuel *et al.*, 2013; Tsigelny *et al.*, 2012). The precise mechanisms of how SNCA aggregation contributes to neurodegeneration, the nature of toxic forms of SNCA and the affected cellular pathways are still unresolved. However, several cytotoxic mechanisms, like proteasome impairment, pore formation, mitochondrial dysfunction, reactive oxygen species (ROS) levels, cytochrome c release and endoplasmic reticulum (ER) stress have been associated with SNCA aggregation process (Figure 7).

Mutant, together with wild-type SNCA, can induce proteasomal dysfunction *in vitro* and *in vivo*; this finding raises the possibility that aberrant α -synuclein may have an impact on protein degradation systems (Petrucci *et al.*, 2002, Snyder *et al.*, 2003). Mitochondria have been previously proposed as cellular targets of SNCA neurotoxicity in numerous publications. Release of cytochrome c from mitochondria induces apoptosis. A proportion of SNCA resides within mitochondria and shows potential of inducing

mitochondrial fragmentation, dysfunction and cytochrome c release leading to cell death in transgenic mice (Nakamura *et al.*, 2011).

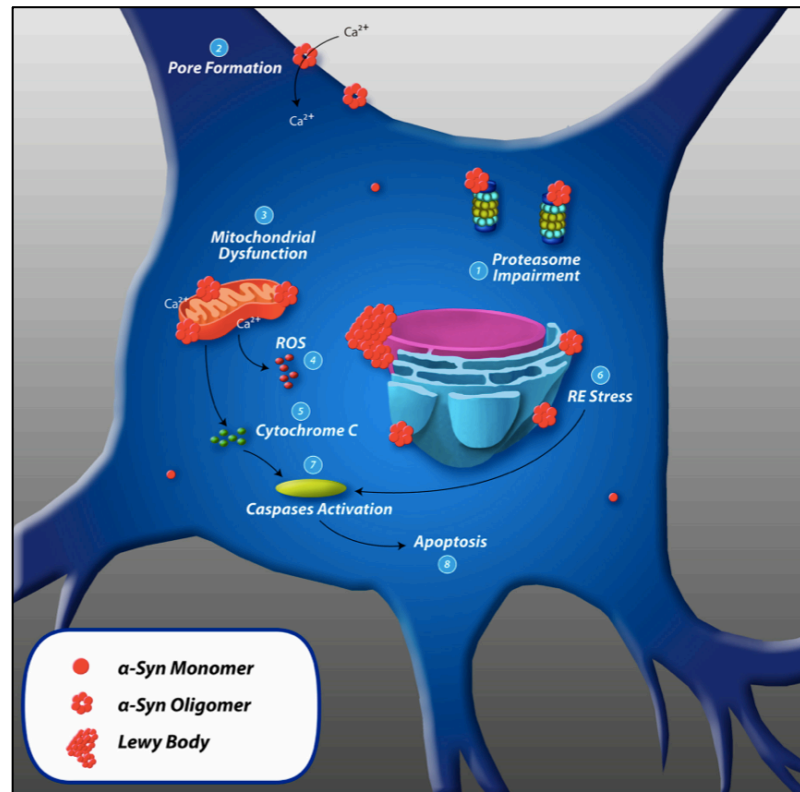

Figure 1.7. Cytotoxic mechanisms of SNCA. (1) inhibition of proteasome activity (2) pore-like structures as non-selective channels (3) and (4) association to mitochondrial membranes and increased ROS levels. (5) accumulation of ROS and Ca^{+2} and release of cytochrome c. (6) association to ER membrane and morphologic dysfunction (7) cytochrome C and ER stress (8) apoptosis (Gallegos *et al.*, 2015).

Mitochondria are also the main cellular calcium stores and any alterations in cellular calcium level contributes to apoptosis of dopaminergic neurons in PD. Additionally the expression of A53T mutant SNCA increases the levels of ROS. ROS is also naturally produced by the metabolism of dopamine in the nigral neurons. Elevated generation of ROS may cause oxidative neuronal damage (Parihar *et al.*, 2008, Smith *et al.*, 2005). Cellular accumulation of misfolded proteins can also lead to chronic ER stress

and triggers unfolded protein response (UPR) to protect cells from accumulation of toxic misfolded proteins (Doyle *et al.*, 2011). Persistent ER stress leads to apoptosis cascade. It has been reported that ER/Golgi transition was delayed due to an antagonistic effect of SNCA on mammalian systems (Thayanidhi *et al.*, 2010). Furthermore, the apolipoprotein repeat motif of SNCA plays a critical role in the membrane translocation of the protein. SNCA oligomers may form pores on cellular membranes and alter the properties of voltage-gated receptors and lead to excess calcium influx. Thus, calcium homeostasis is a potential mechanism of α -synuclein-induced degeneration (Hettiarachchi *et al.*, 2009). It has been reported that mutant SNCA (A53T and A30P) leads to higher levels of pore formation in the SH-SY5Y cells (Furukawa *et al.*, 2006). SNCA also interacts with tubulin, tau and actin proteins in the cytoskeleton. This association may indirectly affect cellular trafficking, axonal transport and synaptic function (Stefanis, 2012).

Apart from the cellular compartments, SNCA is also found in the extracellular fluids, such as in plasma and cerebrospinal fluid. Secreted SNCA can impact neuronal homeostasis and cause neuronal death even in slightly up-regulated levels (Danzer *et al.*, 2011).

1.4.3. Potential Pathogenic Effects of α -synuclein

SNCA is able to form oligomers, fibrils and aggregates, when exposed to pH change, oxidative stress, through over-expression or by interaction with dopamine (Feng *et al.*, 2010). Specific phosphorylation and ubiquitination of SNCA is thought to increase aggregation and form an insoluble state of the protein, as in the case of serine 129 phosphorylation of SNCA changing its solubility properties and enhancing its tendency to aggregate (Walker *et al.*, 2013). Intracellular accumulations of SNCA amyloid fibrils describe synucleinopathies, in which PD is included (Danzer *et al.*, 2012).

As mentioned before, pathologic features of PD are characterized by three main features: First, the progressive degeneration of dopaminergic neurons leading to defects in essential functions; second, the presence of non-motor symptoms, which develop due to degeneration of non-dopaminergic systems and lastly, the propagation and accumulation of

LBs, that mainly contain fibrils of SNCA protein in different parts of the body. Another aspect of SNCA is that it can be present in the extracellular fluids and can be uptaken by cells. Oligomeric-aggregated SNCA is especially prone to uptake and has the potential to “seed” aggregation of endogenous SNCA in the receiving cells (Danzer *et al.*, 2011). This finding was first discovered in the autopsy reports of PD patients who received healthy dopaminergic neuron grafts prior to postmortem analyses. The analyses showed that the serine 129 phosphorylated SNCA and LBs of the host were transmitted to the grafted healthy neurons (Li *et al.*, 2008). It was also shown that the accumulation in the grafted cells was time-dependent, so the transmission to a receiver cell and seeding aggregation procedure takes some time (Brundin *et al.*, 2008). Several follow up studies attempted to replicate and explain these findings in cell and animal models. Introduction of the exogenous SNCA fibrils to various cells over-expressing SNCA increased intracellular SNCA aggregation *in vitro* (Danzer *et al.*, 2009, Luk *et al.*, 2009). An *in vivo* study demonstrated that a single injection of misfolded SNCA into wild type mice could induce neurodegeneration with LB pathology and the selective loss of neurons in the substantia nigra region (Luk *et al.*, 2012). The SNCA transmission finding in humans was also replicated *in vivo*, where human SNCA expressed in mice brain were uptaken by the grafted dopaminergic neurons in the striatum of the transgenic mice (Reyes *et al.*, 2014). Several transmission mechanisms have been proposed for SNCA (Figure 8).

Exosomes are small membrane vesicles released from the cell to the environment; they participate in spreading of the pathogenic proteins in prion diseases and β -amyloid peptide in Alzheimer’s disease. SNCA oligomers are found in exosomal fractions from both neuronal and non-neuronal cells and exosome-associated SNCA is more prone to be uptaken by neighboring cells in comparison to free SNCA oligomeres (Danzer *et al.*, 2012). In another study, an inhibitor that blocks endocytic vesicle formation significantly reduced the transmission of SNCA *in vitro* (Desplats *et al.*, 2009). SNCA can bind to and penetrate through the cellular membrane by its apolipoprotein repeat motif, and this penetrance is not controlled by the receptor-mediated endocytosis or by the endo/exocytosis inhibitors (Ahn *et al.*, 2006). Recently, tunneling nanotubes, that are actin-containing membrane bridges between cells, have been proposed to be involved in intracellular propagation of SNCA, however, they have not yet been implicated in any neurodegenerative disease other than prion diseases. Finally, the release of SNCA fibrils

from a dying cell may also contribute to the extracellular release and transmission to other cells (Gallegos *et al.*, 2015).

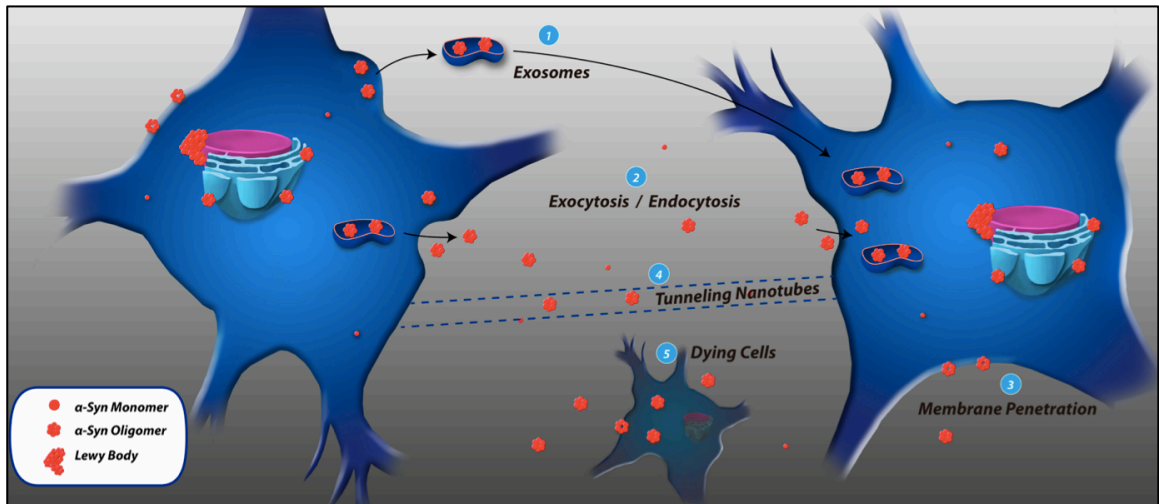

Figure 1.8. Transmission mechanisms of SNCA. (1) presence of SNCA inside exosomes (2) release and uptake of SNCA by exo- and endocytosis (3) SNCA penetrates to the membrane through its N-terminus and passes to cytosol (4) tunneling nanotubes as potential mechanism for SNCA transmission (5) dying cells are important reservoirs for pathological SNCA release to cytosol (Gallegos *et al.*, 2015).

The “prion-like” transmission behavior may be a potential explanation for the well-considered Braak hypothesis where Lewy body pathology is considered to be spreading gradually from the gastrointestinal tract or the olfactory bulb to the cortex during progression of PD (Figure 4). Braak *et al.* reported α -synuclein immunoreactive inclusions in neurons of the gastrointestinal tract. The hypothesis was that an environmental pathogen capable of passing the gastric epithelial might induce SNCA misfolding and aggregation, so that LB pathology may start in the peripheral nervous system and be transferred to the brain via consecutive series of projection neurons (Braak *et al.*, 2006). This environmental pathogen leading to SNCA aggregation may be the uptaken misfolded protein itself.

1.5. Treatment of Parkinson's Disease and Approaches for Therapy

PD is a slowly progressive but irreversible disease. Available pharmacological and non-pharmacological treatments focus on motor symptoms, but do not reverse the neuronal degeneration in the substantia nigra or in the other affected areas. Available pharmacological and non-pharmacological methods of treatment may improve some of the symptoms, however mostly associate with further side effects (Corti *et al.*, 2011). The current gold standard treatment of PD is the dopamine precursor 3,4-dihydroxyphenyl-L-alanine (L-DOPA or levodopa). In contrast to dopamine itself, L-DOPA can cross the blood-brain barrier, thus can enter the remaining dopaminergic and serotonergic neurons where it is converted into dopamine by L-aromatic amino-acid decarboxylase (AADC) (Kageyama *et al.*, 2000, Tanaka *et al.*, 1999). Unfortunately, the efficiency of L-DOPA decreases over time and 40-90 % of patients further develop severe side effects like involuntary movements (dyskinesia), motor fluctuations, hallucinations and psychosis within four to 10 years of drug usage (Manson *et al.*, 2012, Obeso *et al.*, 2004). A more recent, non-pharmacological approach is deep brain stimulation at high frequency, in which electrodes are surgically implanted, stimulating the brain for several years in order to silence the already stimulated neurons in patients and to introduce a new activity to the network (Hammond *et al.*, 2008).

Furthermore, gene-silencing therapies aiming to silence the defective genes associated with PD, may be useful for disease treatment (Tarazi *et al.*, 2014). Total SNCA level is thought to be the major determinant of toxicity, thus, transcriptional, posttranscriptional and degradation regulation of α -synuclein is very important for PD pathogenesis. Accordingly, any attempt lowering the SNCA level may be a reasonable treatment for PD and other synucleinopathies (Stefanis, 2012). LBs and LNs contain high amounts of serine 129 phosphorylated SNCA and increased formation of this phosphorylation enhances tendency to aggregation. Both *in vitro* and *in vivo* studies have shown that inhibiting formation of serine 129 phosphorylated SNCA can prevent toxic consequence, and this has also become a recent therapeutic target for PD (Walker *et al.*, 2013).

1.6. Biomarkers of Parkinson's Disease

Biomarkers are measurable indicators of a biological condition. They can evaluate the presence (trait) or severity (state) of a biological/pathogenic process, pharmacologic response or therapeutic intervention.

Neurodegenerative diseases are heterogeneous, in which exact detection of disease onset and disease activity is difficult, because the affected tissue is not available for examination. In addition, the long presymptomatic phase makes the diagnosis possible only many years after the neurodegeneration starts (Gasser, 2009). In PD for example, many studies demonstrated that at clinical diagnosis, a 60-70 % loss of dopaminergic neurons has already occurred. Early nonmotor symptoms of PD, such as olfactory loss, autonomic dysfunction, sleep disturbance and cognitive and behavioral impairment may reflect the damage starting at the presymptomatic phase and support the Braak hypothesis of neuropathology starting in extranigral, or even extra-central nervous system structures (Berg *et al.*, 2012). As the understanding of the early symptoms of PD advanced, the search for reliable biomarkers that reflect the underlying disease process has increasingly gained attention. This understanding of early symptoms also provides an opportunity to study at-risk individuals, who are expected to develop PD. These individuals would have the best prospects to benefit from any future neuroprotective treatments, based on the fact that the neuronal damage has not occurred in these individuals yet. Furthermore, studying these patients may provide a better understanding to the earliest disease manifestations and thus to the natural course of PD enlightening the underlying mechanisms of the disease.

Numerous studies in recent years demonstrated that the blood gene model has strong predictive value for PD diagnosis and possibly may help to identify individuals at presymptomatic stages. In a study, a protein called osteopontin (SPP1) was increased in the serum and cerebrospinal fluids of PD patients, and higher serum levels were associated with more severe motor symptoms (Maetzler *et al.*, 2007). SPP1 is a glycosylated phosphoprotein that belongs to the small integrin binding ligand, N-linked glycoprotein family of proteins (Fisher *et al.*, 2001). Many functions of the protein suggest a role in the pathogenesis of PD, like its involvement in oxidative stress, mitochondrial impairment, cytokine regulation and apoptosis (Gao *et al.*, 2003, Giachelli and Steitz, 2000, Sodek *et*

al., 2000). Another reported biomarker, detected from a transcriptome-wide scan study, was *ST13*, which stabilizes heat-shock protein 70, a modifier of alpha-synuclein misfolding and toxicity, down-regulated in PD patients (Scherzer *et al.*, 2007). Increased SNCA level and altered phagocytosis were suggested to provide useful biomarkers for PD, due to the findings in transgenic mice and monocytes and fibroblasts isolated from idiopathic or familial PD patients (Gardai *et al.*, 2013). A recent network-based meta-analysis of four independent microarray studies identified the *hepatocyte nuclear factor 4 alpha (HNF4A)* up-regulation and *polypyrimidine tract binding protein 1 (PTBPI)* down-regulation in PD patients. HNF4A is a transcription factor associated with gluconeogenesis and diabetes and PTBPI is involved in the stabilization and mRNA translation of insulin (Santiago and Potashkin, 2015). Despite the increased interest in PD biomarker research and the statistically significant results reported in each PD cohort under study, none of the candidate biomarkers have been reported to be functional in a different PD cohort.

There is no reliable biomarker in PD yet; any ideal biomarker to be defined should have the following qualifications: (i) high sensitivity (true positive rate) and specificity (true negative rate), (ii) satisfactory reproducibility, (iii) easy accessibility and inexpensiveness, (iv) ability to monitor disease progression without being biased by age, compensatory mechanisms or treatments. Identification of such biomarkers would pave the way for a more accurate diagnosis of PD and development of therapeutic strategies. To date, the most mature PD biomarkers for nigrostriatal neurodegeneration are thought to be neuroimaging technologies, however, whether these techniques can objectively assess PD progression or be effective in differentiating parkinsonism is not certain yet (Wang *et al.*, 2013).

2. PURPOSE

The preclinical phase of PD (discussed in the previous chapter) enables the possible identification of biomarkers that could help us to detect individuals at risk and practice neuroprotective therapies. Although the number of studies reporting PD biomarkers has increased in recent years, none of the candidate biomarkers have been further confirmed yet in any PD cohort apart from the study cohort itself. One of the possible reasons for this inconsistency may be the great genetic heterogeneity of the idiopathic PD cohorts under study (Wu *et al.*, 2011).

This thesis aims to identify blood biomarkers of PD in an unpublished large family with an *SNCA* duplication (PARK4), by studying the effects of SNCA gain-of-function on the expression levels of several candidate genes identified from a previous mice transcriptome study and from a global RNA sequencing analyses of the PARK4 family under investigation. A further aim is to examine the candidate biomarkers, identified in the PARK4 family, in distinct idiopathic and presymptomatic PD cohorts, in order to strengthen the relationship of the candidate genes with the common idiopathic (classical) PD.

The PARK4 family provides an important privilege for this study.

- Firstly because, it provides a sufficient number of very homogenous human subjects for statistical analyses.
- The other privileged condition of the family is the specific importance of SNCA in classical PD, which arises the possibility that the identified biomarkers in this family to be applicable in classical PD patients.
- Lastly, the great number of presymptomatic individuals in the family paves the way for identifying a biomarker in the early stages of PD, thus leading to disease diagnosis before the irreversible neuronal cell death has reached the critical threshold.

3. MATERIALS

3.1. Subjects and Samples

Blood samples from a large Turkish PD family with an SNCA duplication were investigated in this study. The family, referred to us by Assoc. Prof. Hülya Tireli from Haydarpaşa Training and Research Hospital, consisted of two affected individuals, twelve presymptomatic mutation carriers and twelve healthy controls (free of the mutation) whose samples were available to us.

DNA samples from 510 idiopathic PD, 258 RLS and 235 healthy controls from Central Europe were kindly provided by Prof. Wolfgang Oertel from Marburg University; RNA samples from a German idiopathic PD cohort containing 15 patients and 13 controls, were kindly provided by Prof. Thomas Gasser from Tübingen University. In addition, blood samples from an RBD cohort of 50 patients and 19 controls were collected in Marburg University in collaboration with Prof. Wolfgang Oertel.

3.2. Genotyping experiments

Genotyping of the PARK4 family was performed by the α -synuclein exon 3 and 4 primers and minor groove binder probes together with the β -globin primers and a TAMARA probe. The promoter region of α -synuclein, containing the Rep1 polymorphic dinucleotide repeat region, was amplified with the corresponding primers in the idiopathic PD, RLS and control cohorts (Table 3.1).

Table 3.1. List of primers and probes used for PARK4 genotyping.

Primer/ Probe ID	Sequence
Q-synuclein-3-VIC Probe	5'-AGCCATGGATGTATTC- 3'
Q-sunuclein-3 Forward Primer	5'-TTCCAGTGTGGTGTAAGAAATTCAT-3'

Table 3.1. List of primers and probes used for PARK4 genotyping (cont.).

Primer/ Probe ID	Sequence
Q-synuclein-3 Reverse Primer	5'-CCTTGGCCTTTGAAAGTCCTT- 3'
Q-synuclein-4-VIC Probe	5'-TGTCTTGAATTTGTTTTTGTAGGC-3'
Q-synuclein-4 Forward Primer	5'-CAG CAATTTAAGGCTAGCTTGGACT-3'
Q-synuclein-4 Reverse Primer	5'-CCACTCCCTCCTTGGTTTTG-3'
B-Globin-FAM Probe	5'-CTCATGGCAAGAAAGTGCTCGGTGC-3'
B-Globin Forward Primer	5'-TGGGCAACCCTAAGGTGAAG-3'
B-Globin Reverse Primer	5'-GTGAGCCAGGCCATCACTAAA-3'
Rep1 Forward Primer	5'- GACTGGCCCAAGATTAACCA -3'
Rep1 Reverse Primer	5'-/56-FAM/CCTGGCATATTTGATTGCAA-3'

List of the TaqMan assays examined in the PARK4 family and in further confirmation studies are listed in Table 3.2.

Table 3.2. TaqMan gene expression assays.

Gene Symbol	Assay ID
<i>SNCA</i>	Hs01103386_m1
<i>GPRIN3</i>	Hs01018439_s1
<i>MMRN1</i>	Hs00201182_m1
<i>LRRK2</i>	Hs00411197_m1
<i>GIGYF2</i>	Hs01084510_m1

Table 3.2. TaqMan gene expression assays (cont.).

Gene Symbol	Assay ID
<i>ATP13A</i>	Hs00223032_m1
<i>ATXN3</i>	Hs01026447_m1
<i>DJ-1</i>	Hs00697109_m1
<i>PINK1</i>	Hs00260868_m1
<i>PARK2</i>	Hs01038318_m1
<i>FBX07</i>	Hs00201825_m1
<i>UCHL1</i>	Hs00188233_m1
<i>GBA</i>	Hs00164683_m1
<i>HTRA2</i>	Hs00234883_m1
<i>PLA2G6</i>	Hs00185926_m1
<i>SNCB</i>	Hs00608185_m1
<i>YWHAG</i>	Hs00705917_s1
<i>YWHAB</i>	HS00793604_m1
<i>YWHAE</i>	HS00356749_g1
<i>CPLX1</i>	Hs00362510_m1
<i>ST13</i>	Hs00832556_sH
<i>GZMH</i>	Hs00277212_m1
<i>SPP1</i>	Hs00959010_m1
<i>PLTP</i>	Hs00272126_m1
<i>HNF4A</i>	Hs00230853_m1
<i>PTBP1</i>	Hs00914687_g1

Table 3.2. TaqMan gene expression assays (cont.).

Gene Symbol	Assay ID
<i>WWP2</i>	Hs00941264_m1
<i>TBP</i>	Hs99999910_m1
<i>CCL5</i>	Hs00982282_m1
<i>PF4</i>	Hs00427220_g1
<i>LILRA2</i>	Hs01597933_g1
<i>NCF1</i>	Hs00165362_m1
<i>ALAS2</i>	Hs00163601_m1
<i>HBA1-2</i>	Hs00361191_g1
<i>CD3G</i>	Hs00962186_m1
<i>CD79A</i>	Hs00998119_m1

DNA and RNA isolations were performed with the related kits. Enzymes/chemicals used in regular and real-time polymerase chain reaction (PCR) analyses are shown in Table 3.3.

Table 3.3. List of materials used in DNA and RNA experiments.

Product	Company
K2E (EDTA) blood tubes	BD Vacutainer
PAXgene blood RNA tubes	Qiagen
MagNa Pure Compact Nucleic Acid Isolation Kit I- Large Volume	Roche
RNaseZAP	Sigma

Table 3.3. List of the materials used for experiments with nucleic acids (cont.).

Product	Company
PAXgene blood RNA kit	Qiagen
DNaseI amplification grade	Invitrogen
Random Primer	Invitrogen
Oligo (dT) Primer	Invitrogen
dNTP Mix	Promega
SuperScripts III Reverse Transcriptase	Invitrogen
FastStart Universal Probe Master	Roche
GoTaq® polymerase	Promega

3.3. Agarose Gel Electrophoresis

All necessary chemicals and buffers for agarose gel electrophoresis are compiled in Table 3.4.

Table 3.4. Materials used in agarose gel electrophoresis.

Product	Company	
10X TBE Buffer	0.89 M Tris-Base (pH 8.3)	Sigma
	0.89 M Boric acid	MP Biomedicals
	20 mM EDTA	Amresco
Agarose	Prona	
Ethidium bromide	MP Biomedicals	
6X loading dye	Fermentas	
DNA ladder	Fermentas	

3.4. Western Blot Analyses

Primary and secondary antibodies used in the study and the companies they belong to are listed in Table 3.5.

Table 3.5. Specifications of the antibodies used.

Protein ID	IgG	Company	Cat. #
α -synuclein	Rabbit	BD Trunsdution Laboratories	BD 610786
complexin-1	Rabbit	Acris	AP51050PU-N
WW domain containing protein 2	Rabbit	Proteintech	12197-1-AP
β -actin	Mouse	Sigma Aldrich	A5441
anti-Rabbit	Goat	BioRad	170-5046
anti-Mouse	Goat	BioRad	170-5047

Materials used for protein isolation, quantification and Western blotting experiments are listed in Table 3.6.

Table 3.6. Materials used in protein experiments.

Buffer	Ingredients	Company
Hemoglobind	-	Biotech
Protease Inhibitor cocktail	-	Roche
BCA protein assay kit	-	(Thermo Scientific)
Acrylamide/Bisacrylamide	30 % A/BA solution	BIO-RAD

Table 3.6. Materials used in protein experiments (cont.).

Buffer	Ingredients	Company
RIPA buffer	50mM Tris-HCl, pH7.4	Sigma
	100mM NaCl	Amresco
	0.1 % SDS	Merck
	1 %Triton-X100	Calbiochem
	0.5 %Sodium deoxycholate	Merck
	2mM EDTA	Amresco
6X Loading buffer	62 mM Tris HCl pH 6.8	Sigma
	9 % SDS	Merck
	30 % glycerol	Sigma
	2 % β - mercaptoethanol	BIO-RAD
	0.004 % bromophenol blue	BIO-RAD
Tris/HCl pH8.9 (1.5M)	181.7g Tris	Sigma
	Adjust pH with HCl	Merck
	Complete to 1Lt dH ₂ O	Milipore
Tris/HCl pH6.9 (0.5M)	60.6g Tris	Sigma
	Adjust pH with HCl	Merck
	Complete to 1Lt dH ₂ O	Milipore
Ammonium Persulfate	10 % APS (w/v) in dH ₂ O	BIO-RAD
TEMED	-	BIO-RAD
TWEEN 20	-	Roche
BSA	-	BIO-RAD
Milk Powder	-	Santa-Cruz
PVDF membrane	-	BIO-RAD
Methanol	-	Merck
TBS buffer (10X)	60.5g Tris	Sigma
	87.6g NaCl	Amresco
	Complete to 1Lt with dH ₂ O	Milipore
TBS-T	100ml TBS 10X	-
	5ml 20 % TWEEN	
	895ml dH ₂ O	

Table 3.6. Materials used in protein experiments (cont.).

Buffer	Ingredients	Company
Transfer buffer	25 mM Tris HCl, pH 8.3	Sigma
	190 mM Glycine	Sigma
	20 % methanol	Merck
Running buffer (10X)	50 mM Tris HCl pH 8.1-8.3	Sigma
	0.1 % SDS	Merck
	192 mM Glycine	Sigma
Lumi-Light Western Blotting Substrate kit	-	Roche
Blocking solution	5 % milk/BSA in TBS-T	-

3.5. Cell Culture experiments

HeLa cells from German Collection of Microorganisms and Cell Cultures (Cat # DSM-No. ACC 57) were cultured in growing medium and routinely frozen in freezing medium (Table 3.7).

Table 3.7. Ingredients of media used in cell culture experiments and related buffers.

Medium Name	Ingredients	Company
Growing Medium	MEM with Earle's Salts	GIBCO® Invitrogen
	10 % Fetal Cow Serum	GIBCO® Invitrogen
	1 % L-Glutamine	GIBCO® Invitrogen
	1 % Non Essential Aminoacids	GIBCO® Invitrogen
Freezing Medium	MEM with Earle's Salts	GIBCO® Invitrogen
	50 % Fetal Cow Serum	GIBCO® Invitrogen
	10 % DMSO	AppliChem

Table 3.7. Ingredients of media used in cell culture experiments and related buffers (cont.).

Medium Name	Ingredients	Company
Dulbecco's Phosphate Buffered Salina	no CaCl ₂ no MgCl ₂	GIBCO® Invitrogen
0.25 % Trypsin-EDTA	-	GIBCO® Invitrogen

The plasmids and their inserted genes, used to transiently transfect the cells, are shown in Table 3.8.

Table 3.8. Plasmid and their inserted genes.

Plasmid	Insert
pcDNA3.1-Entry Vector	No insert (empty vector)
pcDNA3.1- <i>SNCA</i> -WT	Human wild type (WT) <i>SNCA</i>
cDNA3.1- <i>SNCA</i> -A53T	Human A53T mutant <i>SNCA</i>
pCMV6-Entry Vector	No insert (empty vector)
pCMV6- <i>WWP2</i>	Myc-DDK-tagged-Human <i>WWP2</i>

Plasmid preparation materials and the purification, transfection and RNA isolation kits are listed below (Table 3.9).

Table 3.9. Plasmid preparation and transfection materials.

Product		Company
LB medium (1 Lt)	10g Tryptone	Becton-Dickinson
	5g Yeast Extract	Becton-Dickinson
	5g NaCl	Amresco
LB Agar	1Lt LB medium	-
	15g Agar	AppliChem
Kanamycin	100ug/ml in LB Agar	Sigma
Ampicillin	100ug/ml in LB Agar	Sigma
Subcloning Efficiency DH5 α Competent Cells		Invitrogen
GenElute HP plasmid midiprep kit		Sigma Aldrich
Effectene Transfection Kit		Qiagen
RNeasy mini kit		Qiagen

3.6. General Lab Instruments

Laboratory instruments used in this thesis are compiled in Table 3.10.

Table 3.10. General laboratory instruments.

Product	Model and Company
Autoclave	Model ASB260T, Astell
CO ₂ Incubator	Thermo
Sterile Cabin	ESCO

Table 3.10. General laboratory instruments (cont.).

Product	Model and Company
Balances	Model VA124, Gec Avery Model CC081, Gec Avery TE612, Sartorius
Centrifuges	Allegra X22-R, Beckman Coulter Centrifuge 1-15, Sigma Aldrich Centrifuge 2-16K, Sigma Aldrich
DNA Isolation Instrument	MagNA Pure Compact, Roche
Electrophoretic Equipments	Wide Mini-Sub Gel GT, BIO-RAD, Mini-Sub Gel GT, BIO-RAD
Gel Documentation System	GelDoc Documentation System, BIO-RAD
Rotator	Heidolph
Magnetic Stirrer	Hotplates MR3001, Heidolph,
Ovens	MD 554, Microvave Oven, Arçelik BD53, Binder
pH Meter	PB-11, Sartorius
Power Supply	EC250-90, Thermo Scientific
Thermalcyclers	Techgene, Techne, TC-312, Bibby Scientific
Real-Time PCR System	StepOnePlus, Applied Biosystems
Laptop Computer	Latitude, Dell
Microscope	DMI4000 B, Leica Microsystems
Shaker	Duomax Platform Shaker, Heidolph

Table 3.10. General laboratory instruments (cont.).

Product	Model and Company
Heat Block	Thermomixer F1.5 Eppendorf
Refrigerator	4250T, Arçelik
Deep Freezer	(-20°C) 4250T, Arçelik (-80°C) HT5786-A, Hettich
Microscope	DMI4000 B, Leica Microsystems
Spectrophotometer	NanoDrop ND-2000c, Thermo
Stella 2000	Raytest
Sonicator	Bandelin
Vortex	Fisons WhirliMixer Reax Top, Heidolph
Water Bath	Gemo DT104, TEST Laboratuvar Cihazları
Water Purification	Millipore

3.7. General Equipments

The entire lab equipment used in this thesis and the supplier companies are listed in Table 3.11.

Table 3.11. General laboratory equipments.

Product	Model and Company
96-well plate	MicroAmp Fast, Applied Biosystems
Optical Adhesive 96-well plate film	MicroAmp, Applied Biosystems

Table 3.11. General laboratory equipments (cont.).

Product	Model and Company
Multichannel pipettes	Finnpipette F2, Thermo
Pipettes	Finnpipette, Thermo
Pipetor	Pipetus, Hirschmann Laborgerate
Dispensers	Cellstar, Greiner
Filter Tips	Axygen
Tips	Axygen
Eppendorf Tubes	Axygen
Falcon Tubes	Greiner
6-Well plates	Cellstar, Grainer
Petri dish	Cellstar, Grainer
Flasks	Cellstar, Grainer
Cryogenic tubes	Sarstedt
Cell Scraper	Greiner
Glassware	Isolab

3.8. Software

All softwares used in the data analyses and their appliers are compiled in Table 3.12.

Table 3.12. Software and appliers.

Software	Applier
Adobe Acrobat X Pro	Adobe
Adobe Photoshop CS2	Adobe
Excel 2013	Microsoft
Word 2013	Microsoft
EndNote X4	Thomson Reuters
GraphPad Prism 5	GraphPad Software Inc
Image J 1.40g	National Institute of Health
StepOnePlus Software v2.1	Applied Biosystems
XFluor 4	Tecan
NanoDrop 2000	Thermo
Peak Scanner	Life technologies
CLC Main Workbench 6.7	Informet Technologies
GSEA-P	Java

4. METHODS

4.1. Blood collection

Peripheral whole blood samples from the PARK4 family were collected under overnight fasting, first into EDTA tubes and then into PAXtubes. Blood was collected into the EDTA tube first (or into a discard tube, if the PAXtube is the only tube to be drawn), so the interior of the blood collection set could be primed.

4.2. DNA Isolation from Blood

DNA was extracted from 1 ml of EDTA-blood by MagNA Pure Compact Instrument, a robotic system designed for nucleic acid extraction from tissue or blood samples. The procedure followed was according to the instructions in the corresponding kit. DNA samples were further stored at -20 °C.

4.2.1. Agarose Gel Electrophoresis

DNA quality was determined on a 1 % agarose gel. One gram of agarose was dissolved in 100 ml 0.5 X TBE buffer. The DNA-intercalating agent EtBr, enabling visualization of DNA under UV light, was added into the solution with a final concentration of 0.5 µg/ml. The solution was polymerized in an electrophoresis plate at room temperature. After polymerization, the gel was put into an electrophoresis tank with 0.5 X TBE. One µl genomic DNA was mixed with 5 µl of 6 X loading dye, loaded and run at 120 Volt for 20-25 minutes; then, the gels were put under UV light, the images captured and documented.

4.2.2. Spectrophotometry

Measurement of DNA concentrations was done by NanoDrop spectrometer at 260 nm optical density (OD 260). The elution buffer of MagNA Pure Compact Instrument was used as blank. One μ l from each sample was put on the optical tip of the instrument and concentrations were documented.

4.3. RNA Isolation

4.3.1. RNA Isolation from Blood

RNA was extracted from 2.5 ml of blood, collected into the PAXtubes, by PAXgene blood RNA kit according to the manufacturer's instructions. RNA samples were further stored at -80 °C. RNA quality and quantity were determined by spectrophotometry. Only RNA samples passing the quality control criteria were included to the study.

4.3.2. RNA Isolation from Cultured Cells

Cells were gently washed with PBS once, in order to remove cell culture media remnants, and were collected in 300 μ l of PBS using a cell scraper. RNA was isolated from half of the cells (150 μ l), using the RNeasy mini kit, following the manufacturer's instructions. The rest was forwarded to protein isolation.

4.4. DNase Treatment and cDNA synthesis

DNase treatment was performed by DNaseI Amplification Grade and cDNA was amplified using SuperScript III Reverse Transcriptase, 50 μ M oligo (dT) primer and 200 ng/ μ l random primer, following the manufacturer's instructions.

4.5. Polymerase Chain Reaction Analyses

4.5.1. Genotyping Analyses

Quantitative real-time PCR was carried out in a reaction volume of 20 μ l with 25 ng of genomic DNA, 900 nM of primers and 250 nM of probes specific to *SNCA*. All samples analyzed were amplified in duplicates. PCR conditions were 95 °C for 10 minutes, 95 °C for 15 seconds, and 60 °C for 1 minute (40 cycles). The dosages of each amplification, calculated relative to the cycle-threshold (Ct) values of the β -globin and normalized to the Ct values of control (CNT) DNA, was determined by the means of $2^{-\Delta\Delta Ct}$ method (Table 4.1). After applying the $2^{-\Delta\Delta Ct}$ method, two-tailed, unpaired *t*-test in the GraphPad Prism 5 software was used in order to detect the significance of each data.

Table 4.1. Representative $2^{-\Delta\Delta Ct}$ equation for PARK4 subjects and controls.

$\Delta Ct_{PARK4} = \text{Average Ct of SNCA}_{PARK4} - \text{Average Ct of TBP}_{PARK4}$
$\Delta Ct_{CNT} = \text{Average Ct of SNCA}_{CNT} - \text{Average Ct of TBP}_{CNT}$
$\Delta\Delta Ct = \Delta Ct_{PARK4} - \text{Average of } \Delta Ct_{CNT}$
The fold change = $2^{-\Delta\Delta Ct}$

4.5.2. Expression Analyses

Quantitative real-time PCR was used to analyze the transcript levels of the target genes. A total of 25 ng cDNA was used in each PCR reaction with 1 X concentration of the relative TaqMan assay. The PCR conditions were 2 minutes at 50 °C, 10 minutes at 95 °C, 40 cycles of 15 seconds at 95 °C and 1 minute at 60 °C. Expression levels of TBP were used as endogenous control and the expression levels of each sample was normalized to the control cDNA by means of the $2^{-\Delta\Delta Ct}$ method. Statistical significance was calculated using the two-tailed, unpaired *t*-test in the GraphPad Prism 5 software.

Receiver operating characteristics (ROC) curve analysis is a classification method created by plotting the sensitivity (true positives of a diagnostic test) rate against the false positives rates, calculated by 1-specificity (true negatives) rate, at various threshold settings. ROC curve was further applied to combine the profiles of expression change of four candidate genes in 11 mutation carriers versus 8 controls. Roc curve analysis was applied by Prof. Eva Herrmann from Goethe University, Frankfurt.

4.5.3. Rep1 Analyses

The promoter region of *SNCA*, containing the Rep1 dinucleotide polymorphism (accession no. U46895), was amplified with Rep1 forward and reverse primers the end concentrations of the PCR ingredients were 3.5 mM MgCl₂, 0.5 mM dNTPmix, 0.4 μM for each primer, 1 X Colorless GoTaq Reaction Buffer, and 0.5 U GoTaq DNA Polymerase. The end volume was completed to 25μl with dH₂O. PCR cycles included 5 minutes at 95 °C, 30 cycles (45 seconds at 95 °C, 45 seconds at 61 °C, 1 minute and 30 seconds at 72 °C), and 5 minutes at 72 °C.

Amplification quality was determined by agarose gel electrophoresis. Two grams of agarose was dissolved in 100 ml 0.5 X TBE buffer (2 % agarose gel), as described in *Section 4.2*. Repeat sizes were determined by GeneScan Analysis (Macrogen Inc., Seoul, Korea). Fisher's exact test was used for statistical analysis (<http://www.quantitativeskills.com/sisa>).

4.6. GeneScan Analysis

GeneScan analysis, based on capillary electrophoresis, compares the emission of fluorescently-labeled primers in the PCR product with the size standards. Ten μl PCR product from all individuals together with a positive and negative control and the 5' FAM-labeled primer were subjected to GeneScan analysis (Macrogen, Korea). The results were analyzed by PeakScanner Software, using 500 LIZ size standards. Reproducibility of GeneScan analyses was validated by repeating ~10 % of the cohort. An individual

containing the allele1/allele2 genotype was used as internal control in both PCR amplifications and GeneScan analyses.

4.7. Comparative Genomic Hybridization

Comparative Genomic Hybridization (CGH) is a microarray scanning method that uses fluorescence. Two mutation carriers and one control subject from the PARK4 family were analyzed for copy number variations using CGH in collaboration with Prof. Evelin Schröck from Technical University, Dresden (Figure 4.1).

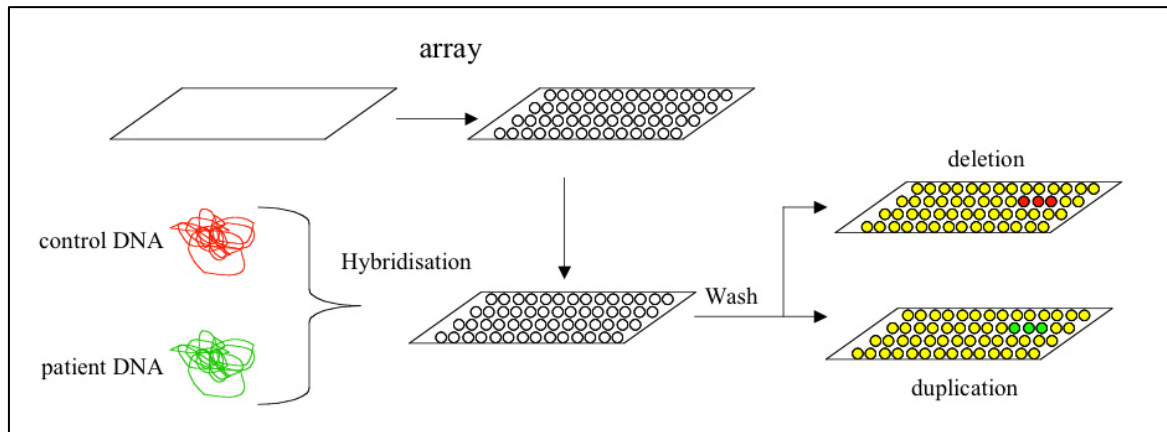

Figure 4.1. Representative scheme of the Comparative Genomic Hybridization method.

4.8. RNA Sequencing

RNA sequencing experiments for the five PARK4 versus five age- and sex-matched healthy individuals were outsourced (Alarcris Theranostics GmbH, Berlin, Germany). RNA libraries were prepared from 500 ng of total RNA according to the Illumina TruSeq standard mRNA protocol, and sequencing was performed by the Illumina HiSeq2500 platform, using paired-end 2x50 bp sequencing mode (Figure 4.2). Sequencing reads were mapped to the human genome reference GRCh37/hg19. All data were publicly deposited at the European Nucleotide Archive (<http://www.ebi.ac.uk/ena>) under the accession number PRJEB8960 / ERP010003.

RNAseq data were analyzed to calculate average fold changes for each gene and to rank them according to the *t*-test statistics. The ranked list of gene symbols was subjected to nonspecific filtering and assessed by Gene Set Enrichment Analysis (GSEA) using GSEA-P (Subramanian *et al.*, 2007, Subramanian *et al.*, 2005).

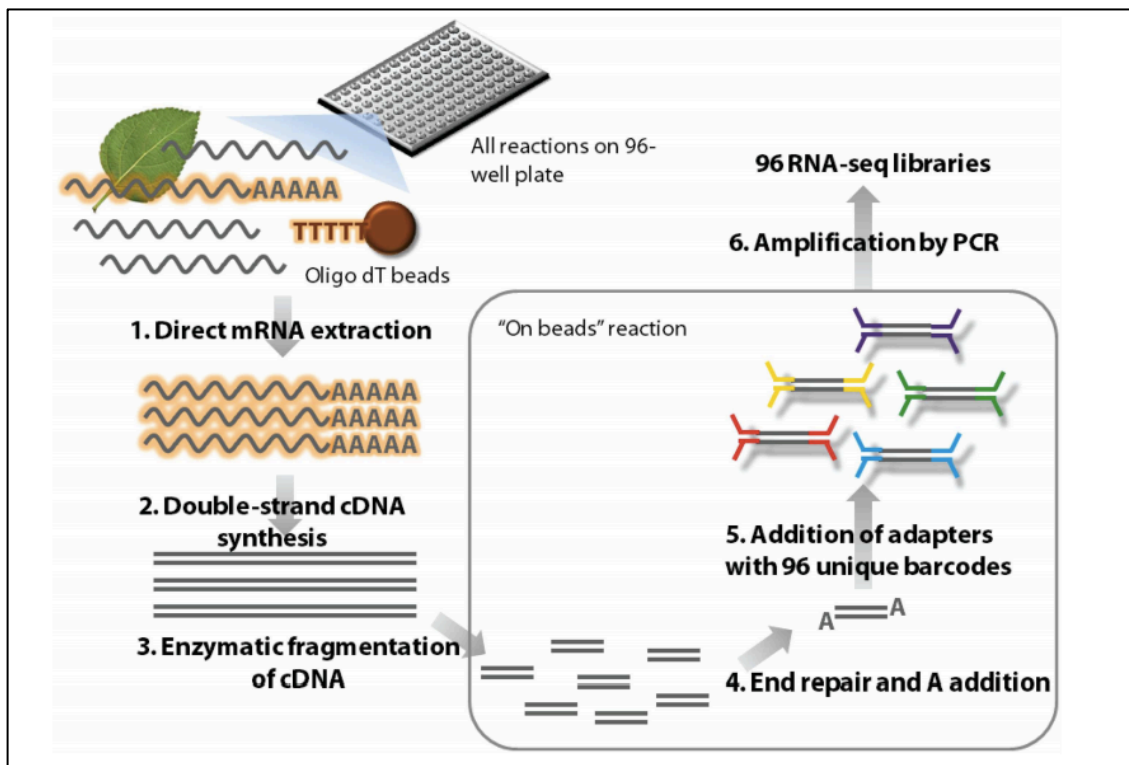

Figure 4.2. Scheme of Illumina TruSeq mRNA library preparation.

4.9. Protein Isolation

4.9.1. Protein Isolation from Blood

Three hundred μ l of the blood samples from the EDTA tubes were lysed with an equal amount of RIPA buffer and one tablet of Complete Protease Inhibitor Cocktail following sonification for 10 sec. The blood lysates were rotated at 4 °C for 30 minutes and centrifuged at 4 °C for 30 minutes at 18,000 g. The supernatants were taken for a further hemoglobin depletion step by Hemoglobind, following the manufacturer's instructions.

Protein concentrations were determined using the BCA protein assay kit and stored at -80 °C for further analyses.

4.9.2. Protein Isolation from cultured cells

Cells were washed with 1X PBS once and were collected in 300 µl of PBS using a cell scraper. Protein was isolated from the half of the cells (150 µl) and the rest was forwarded to RNA isolation. Cells were centrifuged at maximum speed for 1 minute and PBS was removed. The cell pellet was resuspended in 80 µl RIPA buffer and one tablet of Complete Protease Inhibitor Cocktail. Cells were rotated for 20 minutes at +4 °C. Further, cells were resuspended again prior to centrifugation at +4 °C and 18.000 g for 20 minutes. Finally the supernatant was taken and stored at -80 °C. Protein concentrations were determined using the BCA protein assay kit.

4.10. Western Blot Analyses

4.10.1. Western Blotting for Proteins Isolated from Blood

Proteins were diluted to 4 µg/µl and mixed with an equal amount of 2X loading buffer. Samples were incubated at 65 °C for 16 hours prior to loading to the 12 % polyacrylamide gels. Gels were run at 100 V for 15 minutes and then at 130 V until the desired protein marker had reached the chosen position. The proteins on the gel were transferred to a PVDF membrane at 50 V for 90 minutes. The membrane was blocked in 5 % milk powder, incubated with primary antibodies against SNCA (1:500) and actin (1:10.000) and visualized using the enhanced chemiluminescence method. Densitometric analysis was carried out by the ImageJ software. Each density value of target (SNCA) was divided to the value of its internal control (actin). Further, normalized values were divided to the average of normalized values of the CNTs (Table 4.2). Significance of the fold changes were further calculated using the two-tailed, unpaired *t*-test in the GraphPad Prism 5 software.

Table 4.2. Calculating fold changes of the proteins in WB analyses.

Normalized Value _{PARK4} = Density Value of SNCA _{PARK4} / Density Value of Actin _{PARK4}
Normalized Value _{CNT} = Density Value of SNCA _{CNT} / Density Value of Actin _{CNT}
Fold Change _{PARK4} = Normalized Value _{PARK4} / Average of Normalized Values _{CNT}
Fold Change _{CNT} = Normalized Value _{CNT} / Average of Normalized Values _{CNT}

4.10.2. Western Blotting for Protein Isolated from Cells

25 µg of protein was mixed with the required amount of 6X loading buffer. Samples were boiled for 2 minutes prior to loading to 10 % polyacrylamide gels. Western blot analyses were carried out as described in *Section 4.10.1*. Primary antibodies used were against SNCA (1:2000), WWP2 (1:1000) and actin (1:10.000). Statistical significance of the data was calculated using the one-way ANOVA (post test: Tukey) tool of the GraphPad Prism 5 software.

4.11. Cell Culture Analyses

HeLa Cells were used in the cell culture analyses in this thesis. HeLa cells are originally derived from Lacks' tissue of a cancer patient and are commercially available.

4.11.1. Maintenance of HeLa Cells

HeLa cells were cultured in 25 cm² flasks in 3 ml MEM + Earle's Salts medium containing 1 % L-glutamine, 1 % non-essential amino acids and 10 % FCS at 37 °C with 5 % CO₂. Upon reaching ~80 % confluency, HeLa cells were split in 1:3 (mondays and wednesdays) and 1:6 (fridays) ratios. For cell splitting, first cell culture medium was removed and cells were gently washed with 1X PBS. Then, cells were incubated with 1 ml of 0.05 % trypsin-EDTA at 37 °C for 2 minutes. After cell detachment was confirmed by visualizing at the microscope, culture medium was added and cells were split at the desired ratio in new cell culture flasks.

4.11.2. Cell freezing

HeLa cells were frozen as stocks until further usage. Freezing was performed with ~80-90 % confluency in 75 cm² flasks. Cells were trypsinized, resuspended in 10 ml cell culture medium and transferred into 15 ml Falcon tubes. Cells were pelleted by centrifugation at 500 g for 3 minutes. Cell pellet was resuspended in 2 ml of freezing medium containing 10 % DMSO, 40 % MEM + Earle's Salts medium, and 50 % FCS. The cells suspension was stored in 1 ml cryogenic tubes and for 2 hours at -20 °C before the final storage at -80 °C.

4.11.3. Cell thawing

The frozen cryogenic vials were thawed in a water bath at 37 °C, immediately mixed with 10 ml of cell culture medium and centrifuged at 500 g for 3 min. Later, the cell pellet was resuspended in 10 ml of cell culture medium, divided into three 25 cm² flasks, and kept in the incubator for maintenance.

4.11.4. Transfection of Cells

Plasmid DNAs for *WWP2* were purchased from Amsbio, USA and plasmid DNAs for SNCA were kindly provided by Dr. Suzana Gispert (Gispert, Del Turco et al. 2003) (Figure 4.3).

Bacterial transformation was applied to 100 µl of Subcloning Efficiency DH5α Competent Cells following the manufacturers instructions. 100 µl of transformed bacteria were plated on LB-Agar plates containing 100 µg/ml antibiotic and incubated overnight at 37 °C. The following day, a bacteria colony was picked from each agar plate using a 10 µl sterile tip and was grown in 3 ml LB medium with 100 µg/ml antibiotic overnight at 37 °C with continuous shaking at 250 rpm. Next day, bacteria grown in the media were forwarded GenElute HP plasmid midiprep kit, following the manufactures instructions.

HeLa cells were plated 200.000 cells per dish, 24 hours prior to transfection. Transient transfection with plasmids was performed using the Effectene kit with following instructions: 1 μg of a single plasmid or 0.5 μg of each plasmid solutions for double transfection were used and the volume was completed to 100 μl using EC buffer. Then, 3.2 μl enhancer solution was added and incubated at RT for 4 minutes. Later, 2.5 μl of Effectene was added and incubated for 8 minutes at RT. Finally, the transfection solution was mixed with 800 μl of cell culture medium and slowly added to the cells. Cells were analyzed 24 h after transfection.

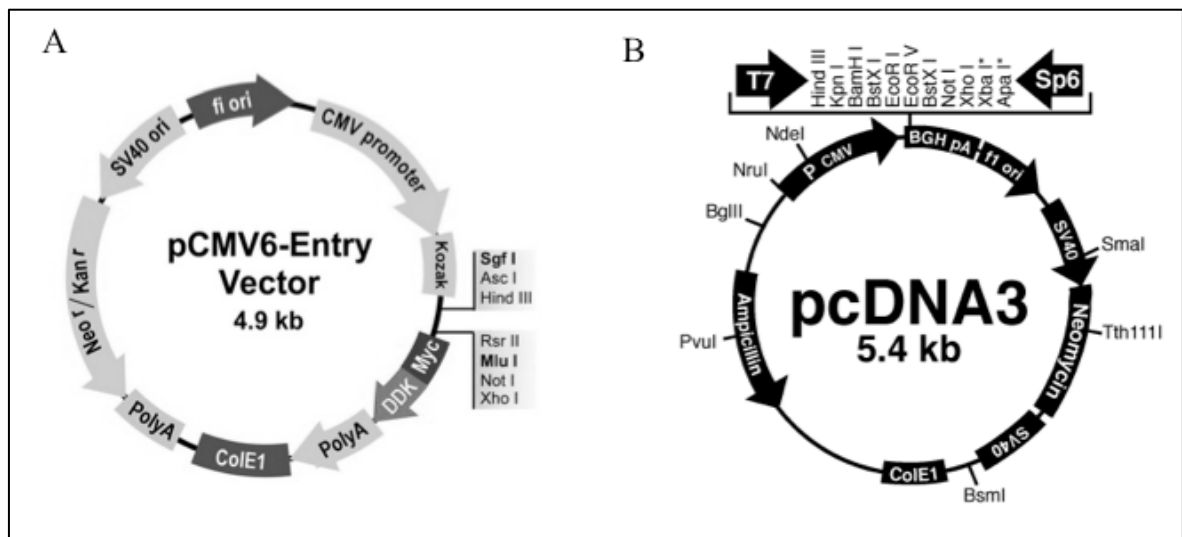

Figure 4.3. Empty plasmid-DNA maps. A. pCMV6-entry vector for *WWP2* inserted between SgfI and MluI. B. pcDNA3.1-entry vector for WT and A53T *SNCA* inserted between the KpnI and NotI restriction sites.

5. RESULTS

5.1. Genotyping of the PARK4 Family

The family diagnosed with PD was referred to NDAL laboratory by Assoc. Prof. Hülya Tireli from Haydarpaşa Training and Research Hospital. The index case of the family was a female, aged 51, with seven years of disease duration. Symptoms were rigidity, resting tremor and bradykinesia, having 60 months of Levodopa-treatment with good benefit, but dyskinesias. The PARK4 mutation in this family was first described in our laboratory with semi-quantitative multiplex PCR and multiplex ligation-dependent probe amplification of *SNCA* exons 3 and 4 (Pirkevi, 2009). For further analyses, blood was collected from individuals of the fourth generation of the PARK4 family, who were under 50 % risk due to having an affected parent (Figure 5.1). Written consent for participation was obtained from each individual and genetic counseling was given. Genotyping studies defined 14 mutation carriers (PARK4), two of whom had already manifested PD, and 12 healthy controls (CNT). Ages of onset of the two patients were 51 and 47 years and the average age of disease onset of the family was 55 years (between 48-70 years). Female to male ratio of the PD patients and the presymptomatic mutation carriers in the family was five to nine and eleven to nine, respectively.

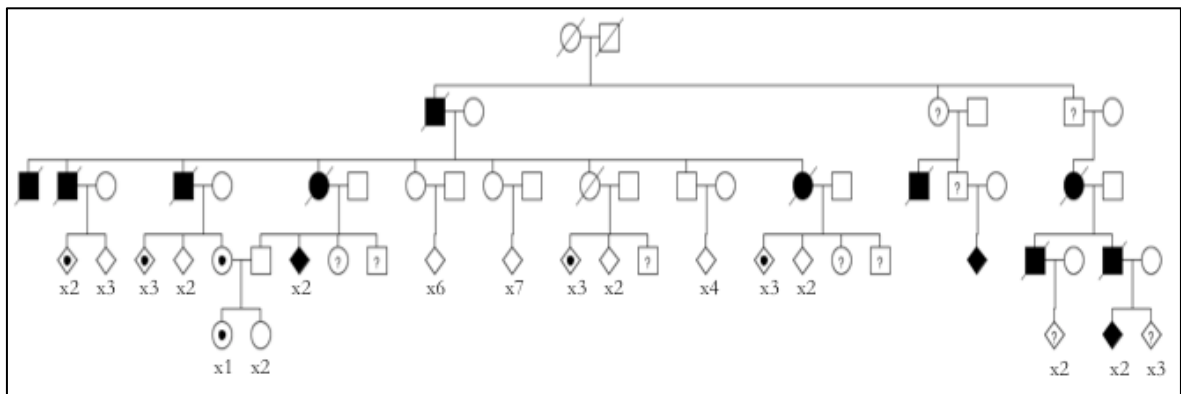

Figure 5.1. The PARK4 family pedigree. The digits indicate the number of individuals of a certain genotype. Patients are shown in black, presymptomatic mutation carriers are represented with a black dot, and a question mark is used for an unknown genotype.

In order to detect duplication borders of the *PARK4* mutation, two *PARK4* individuals were assessed for copy number variation using CGH microarray. CGH showed duplication on chromosome 4 in two distinct regions (29 and 10 kb). Additional to *SNCA*, two flanking genes *GPRIN3* and *MMRN* were also duplicated due to a recombination event within the healthy normal allele. *GRID2* showed only a partial duplication, in which the start codon of the gene was not affected (Figure 5.2).

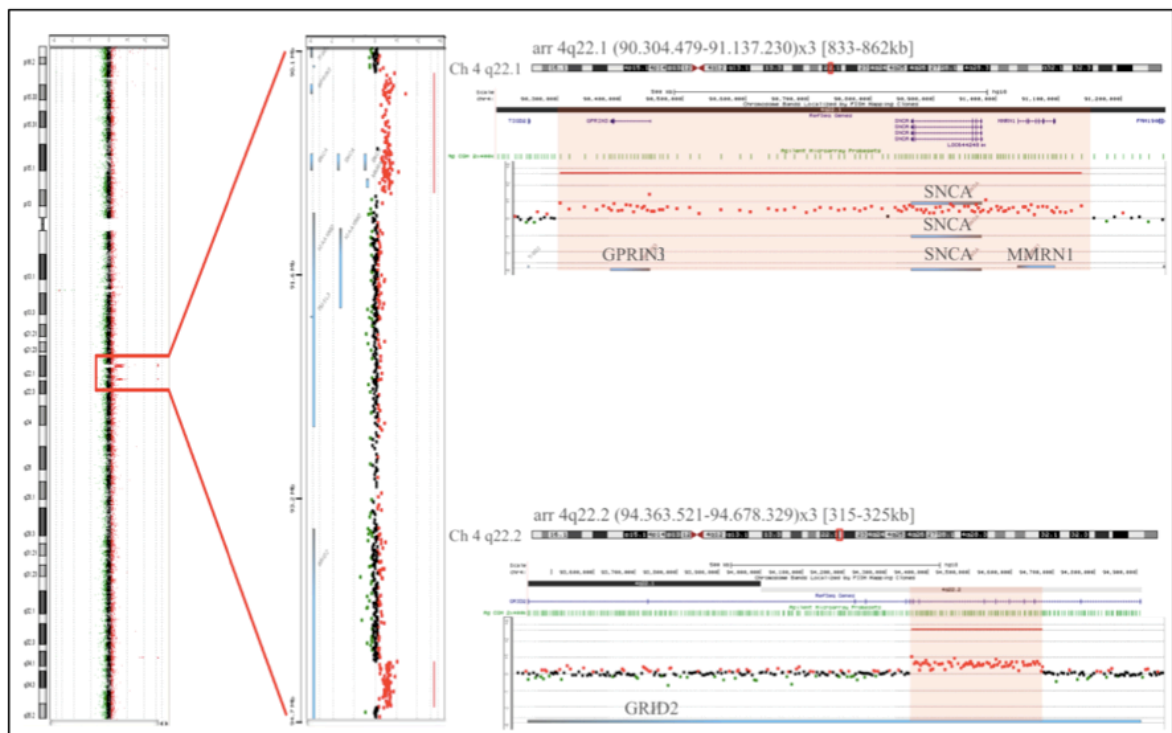

Figure 5.2. CGH result representing two duplicated regions (29 kb and 10 kb) on chromosome 4 of a *PARK4* individual. Red dots represent duplicated loci, blue lines indicate the duplicated genes.

5.2. Taqman Assay Selection and Normalization of the Data

Three different Taqman assays, used to detect *SNCA* mRNA levels, were separately normalized to six different housekeeping genes in order to select a combination with the least standard deviation (Figure 5.3). Taqman assays Hs01103386_m1 (*SNCA*) and Hs99999910_m1 (*TBP*) were selected as the best combination.

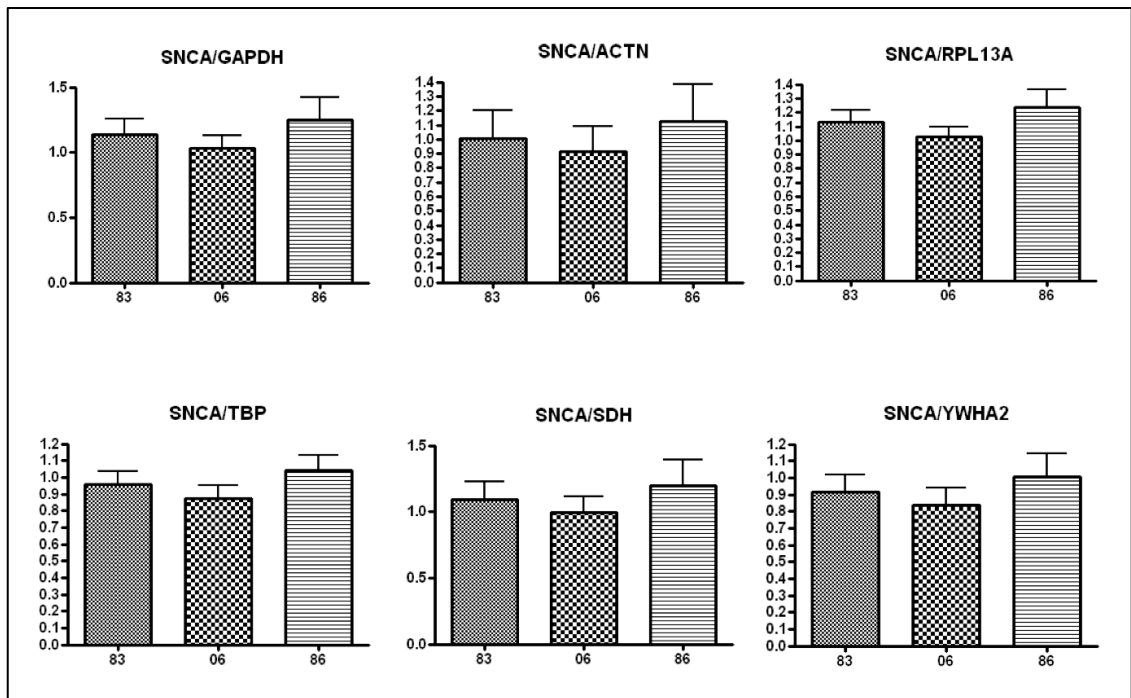

Figure 5.3. Bar graphs representing three different *SNCA* Taqman assays (83, 06 and 86), normalized to different house keeping genes (*GAPDH*, *ACTN*, *RPL13A*, *TBP*, *SDH* and *YWHA2*).

5.3. Effect of Duplication on mRNA and Protein Expression

The effect of duplication on transcription was questioned with qRT-PCR analyses. All three duplicated genes, *SNCA*, *GPRIN3* and *MMRN1*, showed an approximately 1.5 fold increase in blood mRNA levels of PARK4 individuals of the family (Figure 5.4). Only *GPRIN3* mRNA upregulation in blood displayed significant changes (p value < 0.0001***).

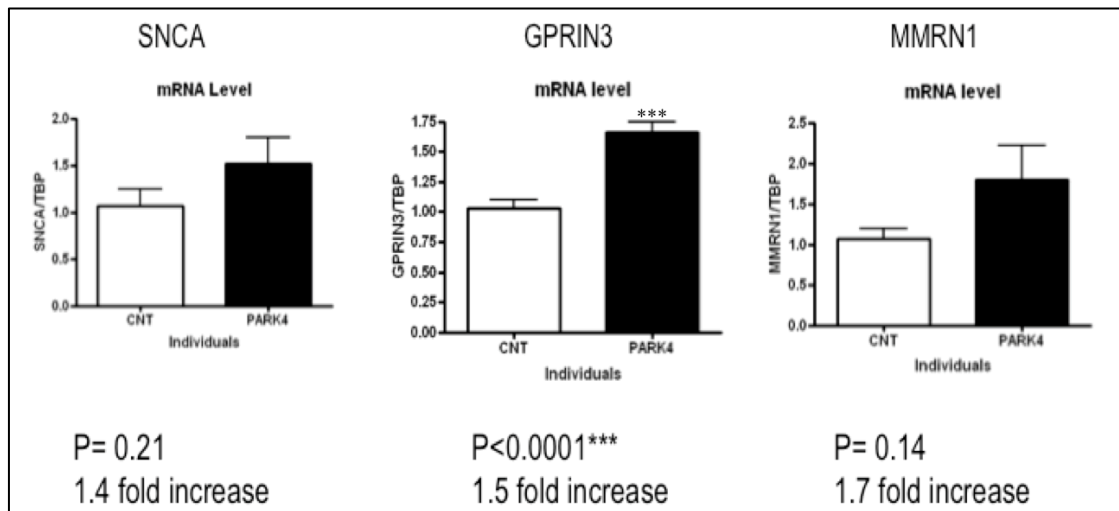

Figure 5.4. Bar graph demonstration of three duplicated genes representing the fold changes between the PARK4 individuals and their healthy relatives (CNT).

SNCA mRNA was further normalized to the constitutive genes, specific to blood cell types, in order to check *SNCA* transcription specificity to any cell type. SNCA mRNA expression was present in all blood cell types and SNCA upregulation was not found to have significant specificity to any certain cell type.

Table 5.1. SNCA transcription changes calculated within each blood cell type.

Blood Cell type	Constitutive Gene	Fold Increase in PARK4	<i>p</i> Value
Platelets	<i>CCL5</i>	1.15	0.53
	<i>PF4</i>	1.58	0.15
Monocytes	<i>LILRA2</i>	1.29	0.35
Granulocytes	<i>NCF1</i>	0.97	0.92
Reticulocytes	<i>ALAS2</i>	1.33	0.49
T-lymphocytes	<i>HBA1-2</i>	1.45	0.42
B-lymphocytes	<i>CD3G</i>	1.47	0.27
	<i>CD3G</i>	1.47	0.27

Western blot analyses of proteins, isolated from PARK4 and CNT blood samples, showed a significant 1.3 fold increase in the monomeric form of SNCA protein in PARK4, representing the duplication (p value: 0.01*). The change in dimer levels of the protein was not significant (Figure 5.5).

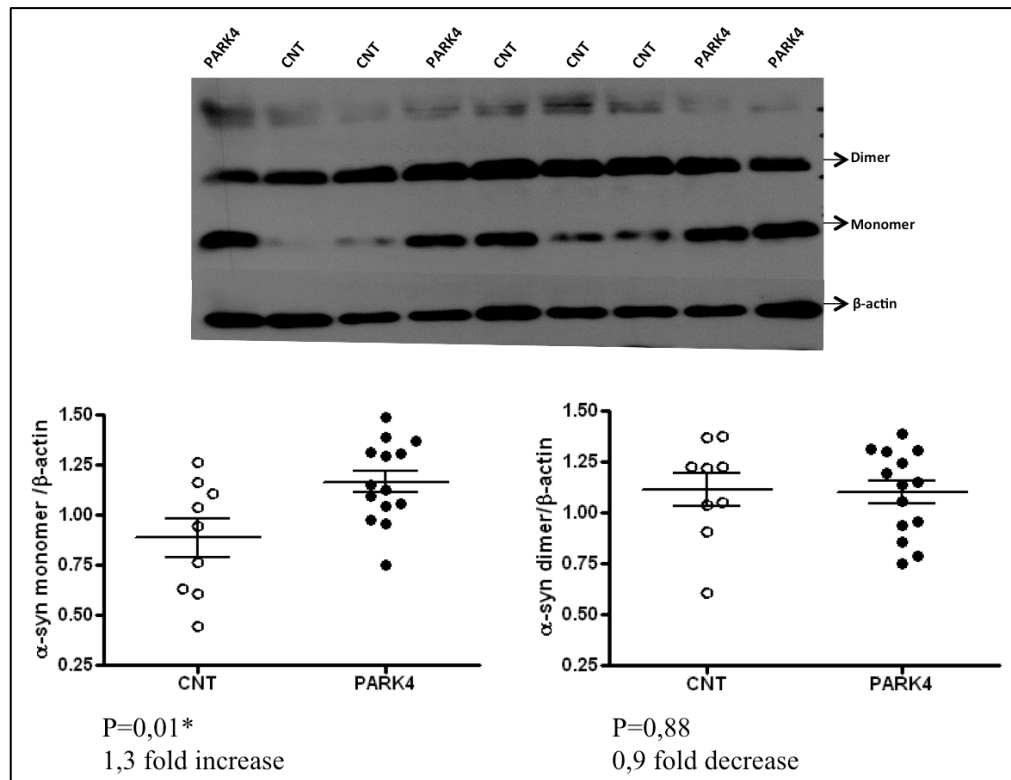

Figure 5.5. Western blot analyses representing the SNCA dimer and monomer levels in PARK4 and CNT individuals and the graph demonstrations of the results.

5.4. Effect of PARK4 Mutation on Candidate Biomarkers

The SNCA duplication effect on the mRNA expression levels of approximately 70 genes, showing significant changes from age 6 to 18 months in global transcriptome analysis of mice overexpressing human A53T-SNCA, was examined in the PARK4 family (Kurz *et al.*, 2010). Only results of the well-known PD genes and the genes that have an expression change with trend significance are represented in Figure 5.6.

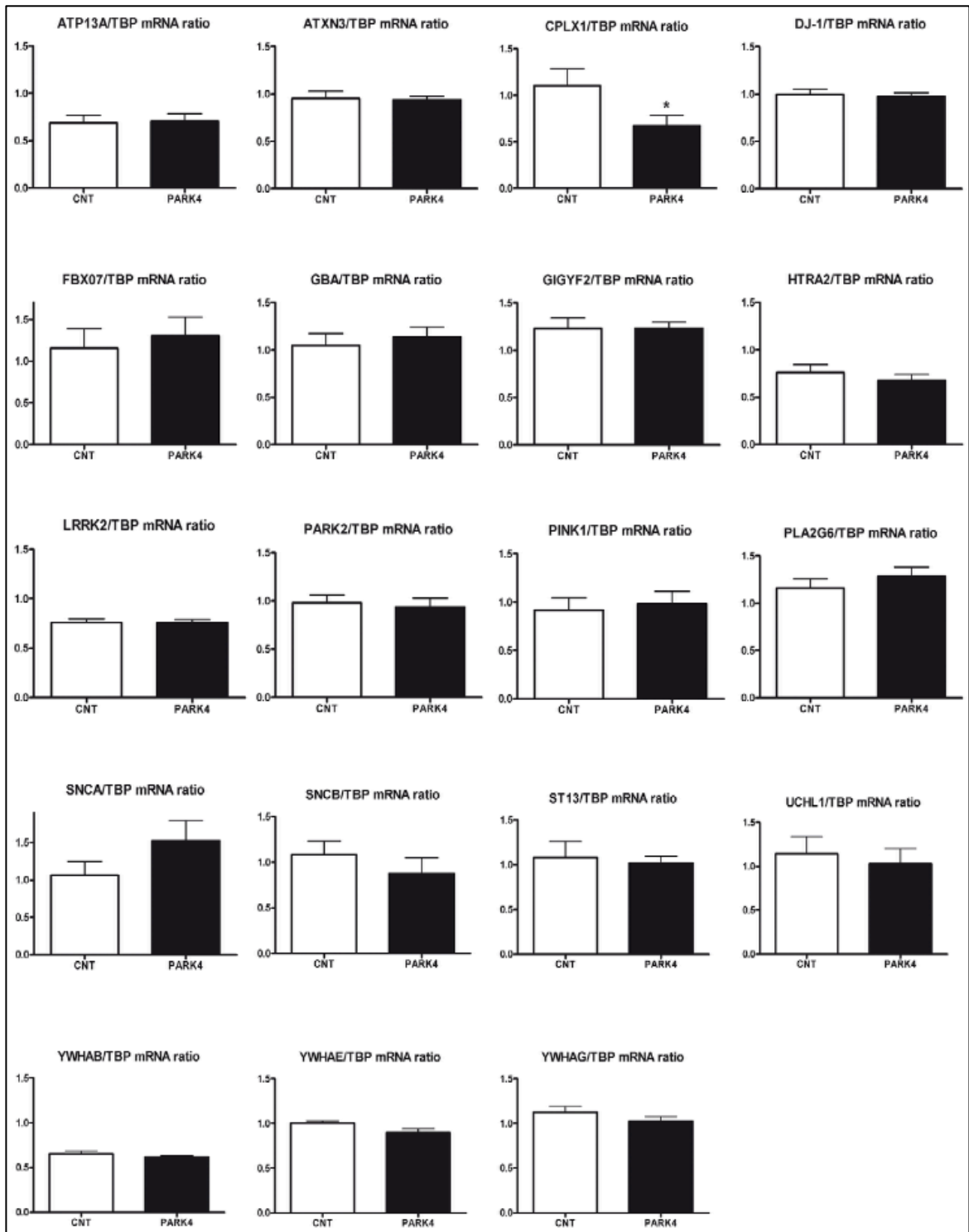

Figure 5.6. Expression differences of the downstream genes affected by the SNCA duplication, in PARK4 and CNT. Statistical significance is illustrated by an asterisk.

The results showed that neither the well-known PD genes (represented by black bars in Figure 5.7), nor the previously suggested PD biomarker *ST13*, were affected by the *PARK4* mutation. The *SNCA*, *SNCB* and the *YWHAG*, *-B* and *-E* genes showed a trend-significance in their expression changes. The only significant expression change was observed in the *CPLX1* gene (Figure 5.7).

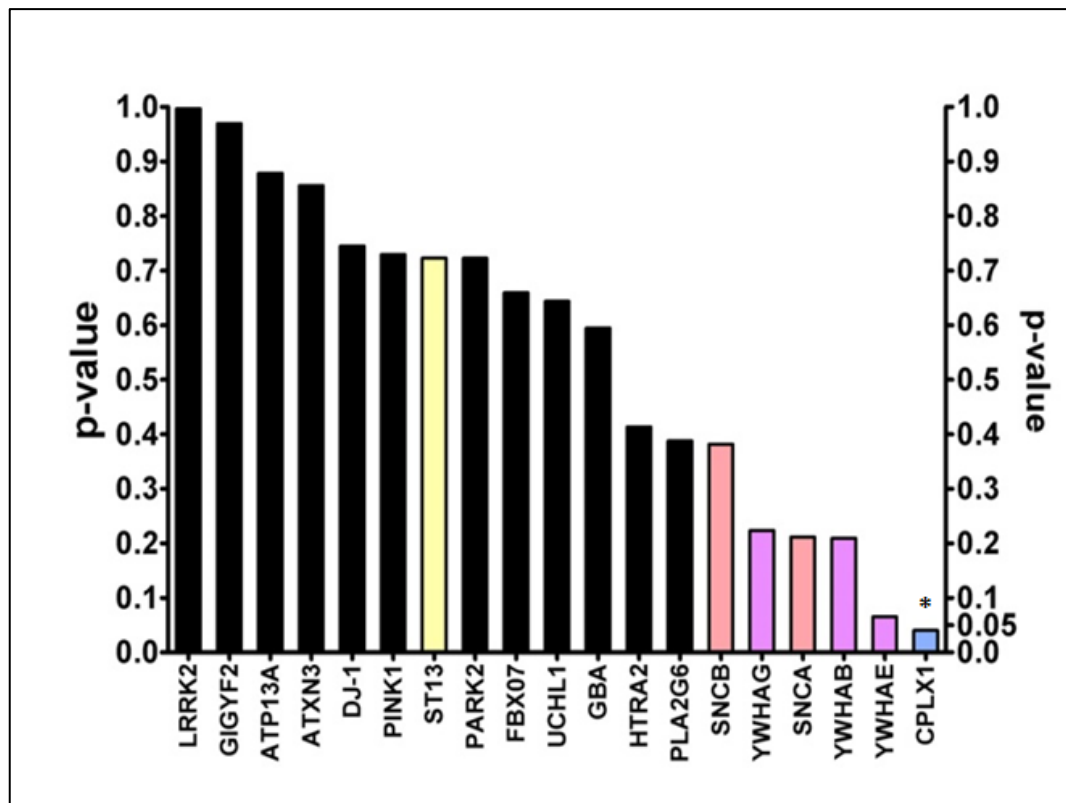

Figure 5.7. Distribution of significance of the effect of *SNCA* duplication on mRNA expressions of downstream genes. Statistical significance is illustrated by an asterisk.

Since only one of the candidate biomarkers showed a significant regulation, ROC curve analysis was applied to combine the profiles of four best candidate biomarker expression changes (*CPLX1*, *YWHAЕ*, *YWHAB* and *YWHAG*). The ROC curve analyses showed predictive diagnostic value with high sensitivity and specificity and a misclassification rate of 12.5 % (Figure 5.8). The accuracy of the test depends on how well the test separates the groups being tested (*PARK4* and *CNT* in the case of this study), and the accuracy is measured by the area under the ROC curve.

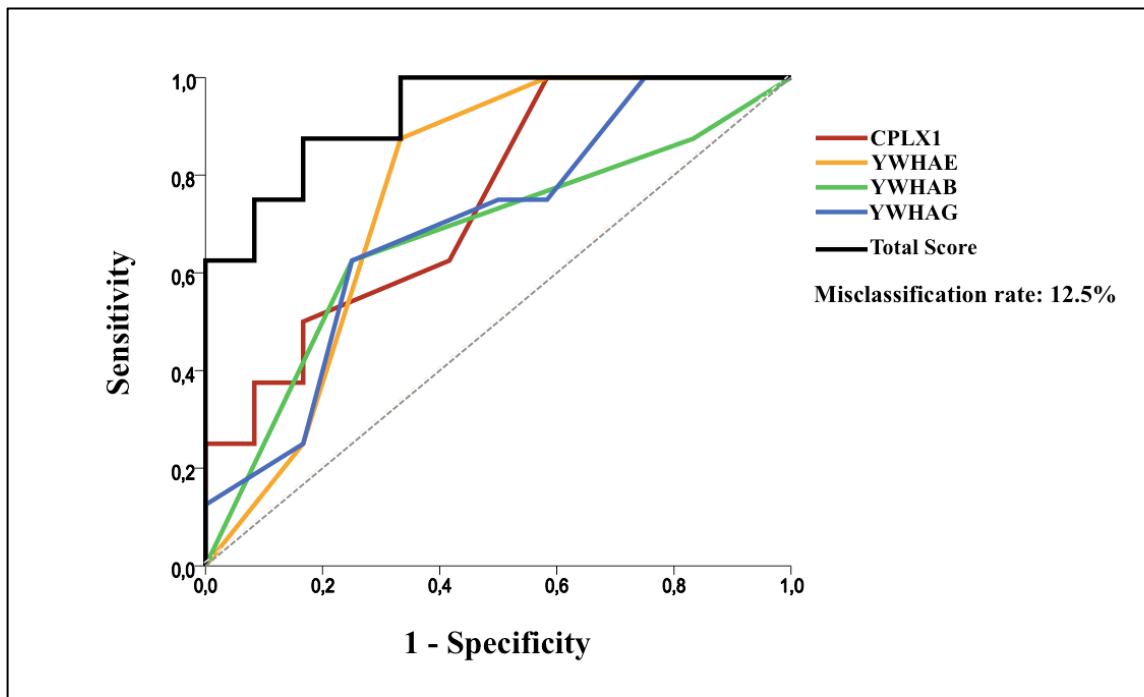

Figure 5.8. ROC curve analysis of *CPLX1*, *YWHAE*, *YWHAB* and *YWHAG*. Sensitivity is the rate of true positives and specificity is the rate of true negatives. 1-specificity gives the rate of false positives. Misclassification rate of the diagnostic test is 12.5 %.

The best three, *CPLX1*, *YWHAE* and *YWHAB*, mRNA expressions were tested in an idiopathic PD (IPD) cohort (13 CNT vs 15 IPD) in order to check if their expression profiles were similar to the *PARK4* family. None of the expression changes were found significant in IPD. Although being insignificant, the *CPLX1* expression was downregulated as in the case of the *PARK4* family. However, *YWHAE* was upregulated as opposed to the previous results from the family and *YWHAB* did not show any change in IPD when compared to CNT (Figure 5.9). Thus, *YWHAE* and *YWHAB* were not subjected to further analyses since their expression profiles were not consistent in different PD cohorts.

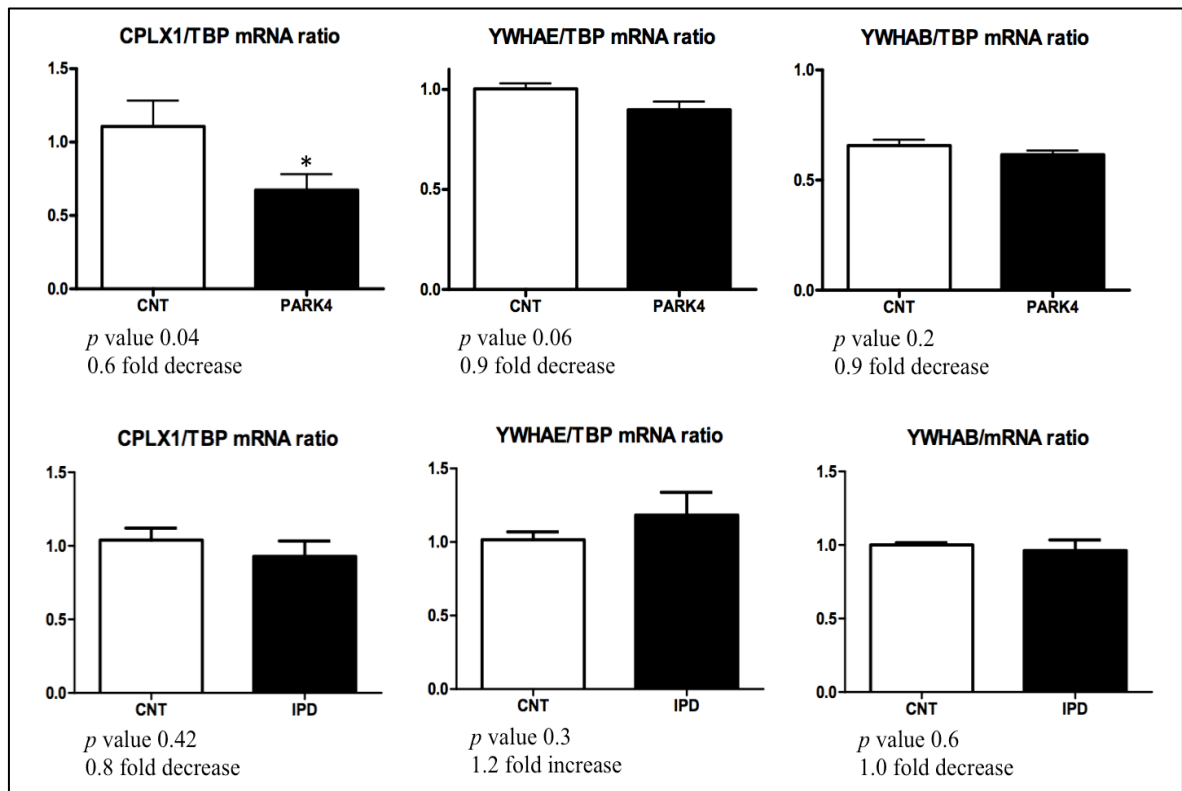

Figure 5.9. mRNA expression changes of *CPLX1*, *YWHAE* and *YWHAB*, compared in the PARK4 family and IPD.

5.5. Effects of Parkinson's Disease on *CPLX1*

Complexin 1 encodes for a protein that binds to SNARE complex and has activating and inhibitory functions. *CPLX1* was the only significantly changed gene, obtained from the PARK4 family, with a downregulation in the mRNA expression level in PARK4 individuals (0.6 fold; p value: 0.04). Further investigations of *CPLX1* expression showed an insignificant 0.8 fold downregulation in IPD (13 CNT vs 15 IPD) and a significant 0.8 fold decrease (p value: 0.02) in an RBD cohort, which represents presymptomatic PD (19 CNT vs 50 RBD). SNCA mRNA expression levels detected in PARK4, IPD and RBD demonstrated that the downregulation in *CPLX1* mRNA level is not a result of SNCA upregulation and that it occurs in PD patients and presymptomatic individuals regardless of the SNCA level (Figure 5.10).

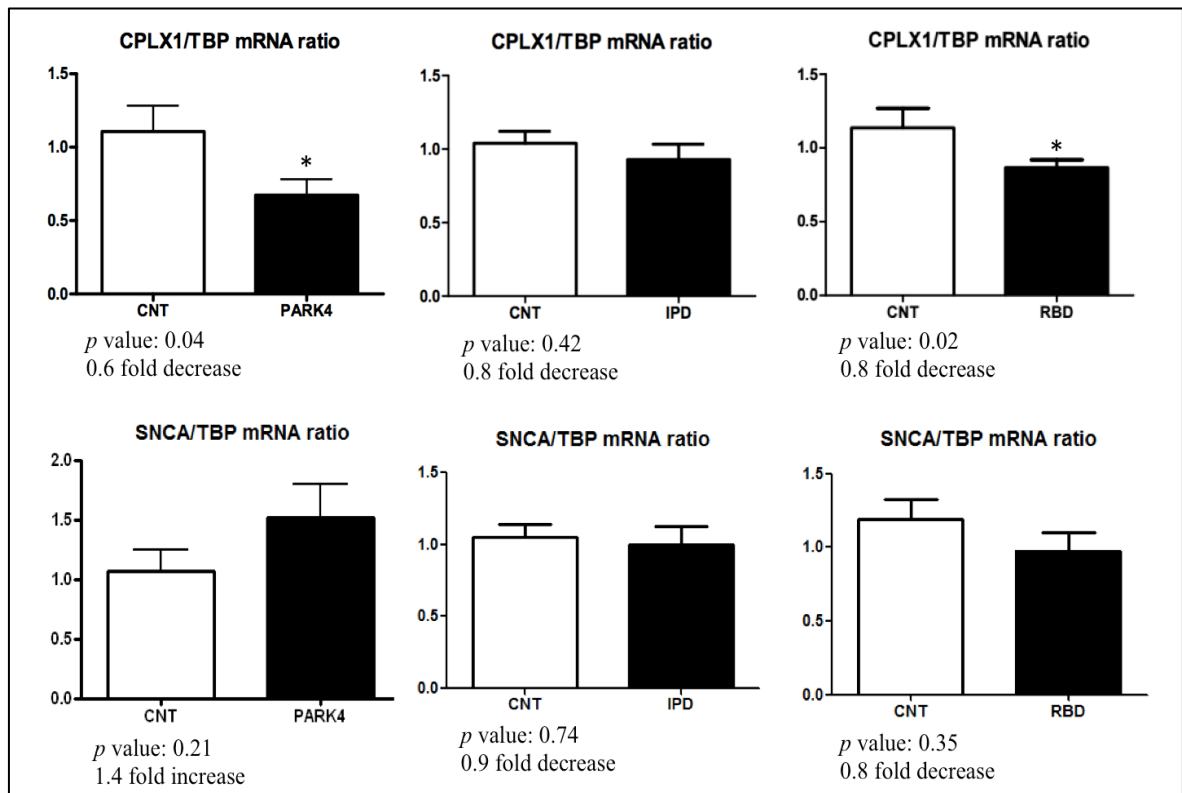

Figure 5.10. Bar graphs representing the mRNA expression changes of *CPLX1* in PARK4, idiopathic PD (IPD) and presymptomatic PD (RBD) individuals compared to their healthy relatives (CNT). Statistical significance is illustrated by an asterisk.

Western blot analyses for proteins, isolated from PARK4 and CNT blood samples, failed to demonstrate any protein bound to CPLX1 antibody, due to insufficient amount of blood CPLX1 concealed by the abundant levels of hemoglobin in blood.

In the framework of this study, Cplx1 protein levels were further investigated in PD mice models by Dr. Suzana Gispert. Two independent mouse lines of inbred FVB/N background with approximately 1.5 fold overexpression of human A53T-SNCA in nigrostriatal dopaminergic neurons (PrPmtA and PrPmtB) and mice with *Snca* knockout in 129/SvEv background (*Snca* KO) were analyzed. Despite the significant downregulation of Cplx1 mRNA levels, protein levels were significantly upregulated in PrPmtA, PrPmtB and *Snca* KO mice (Figure 5.11) (Gispert *et al.*, 2014). These results also implicated that the mRNA downregulation and protein upregulation of CPLX1 occur regardless of the SNCA levels.

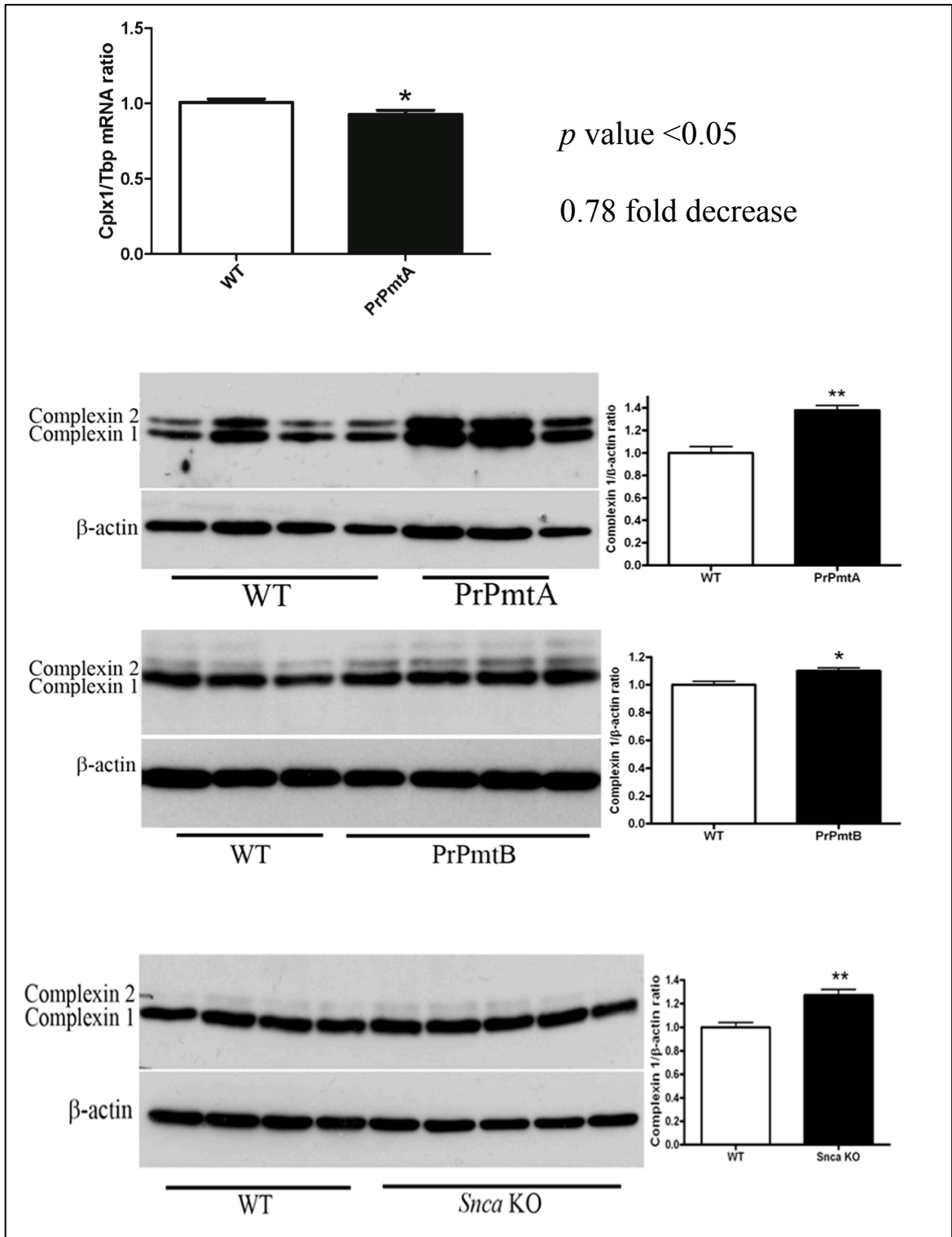

Figure 5.11. Demonstration of Cplx1 mRNA downregulation in PrPmtA mice and the Western blot analyses of Cplx1 protein, being significantly upregulated in PrPmtA, PrPmtB and Snca KO midbrain/brainstem (adopted from Gispert *et al.*, 2014).

5.6. RNA Sequencing Analysis

Global expression profiling data obtained from RNA sequencing of five PARK4 versus five age- and sex-matched healthy individuals from the PARK4 family were analyzed in search of new biomarker candidates. Data was first evaluated bioinformatically with GSEA in order to identify pathway dysregulations. GSEA showed no significant downregulated pathways, however, several strong upregulations, the immune system being outstanding, were documented (p values: 0.0 and q values: 0.0) (Table S1). Some genes with strong effects within these significantly upregulated pathways; lysosome, immune and lipid pathways, were studied as promising biomarker candidates and were further validated with qRT-PCR in the PARK4 family and RBD cohort.

Cathepsin G-like 2 (*GZMH*) from the lysosome pathway (upregulation to 204%, p value: 0.04) was selected because the lysosomal enzymes cathepsin D and B were previously implicated in degradation and aggregation of SNCA (Crabtree *et al.*, 2014, Tsujimura *et al.*, 2014). The immunity regulator osteopontin (*SPP1*) (upregulation to 244%, p value: 0.01) was chosen since it was identified as a biomarker of PD in blood serum, cerebrospinal fluid, microglia, and affected neurons (Iczkiewicz *et al.*, 2006, Maetzler *et al.*, 2007, Shi *et al.*, 2015). The similarly strong upregulation (to 189%, $p = 0.08$) of the phospholipid transfer protein (*PLTP*) was further validated due to its associations with ataxias, Alzheimer's disease, tau phosphorylation, and lipopolysaccharides (Albers *et al.*, 2012, Dong *et al.*, 2009, Gautier and Lagrost, 2011).

GZMH, *SPP1*, *PLTP* mRNA expressions showed significant upregulations in PARK4 blood (p value: 0.009 1.8 fold increase, p value: 0.02 2 fold increase, p value: 0.02 1.7 fold increase, respectively), but could not discriminate presymptomatic PD (RBD) (p value: 0.03 1.2 fold increase, p value: 0.4 1.2 fold increase, p value: 0.7 1.04 fold increase, respectively), while *CPLX1* was useful as biomarker in both cohorts (Figure 5.12).

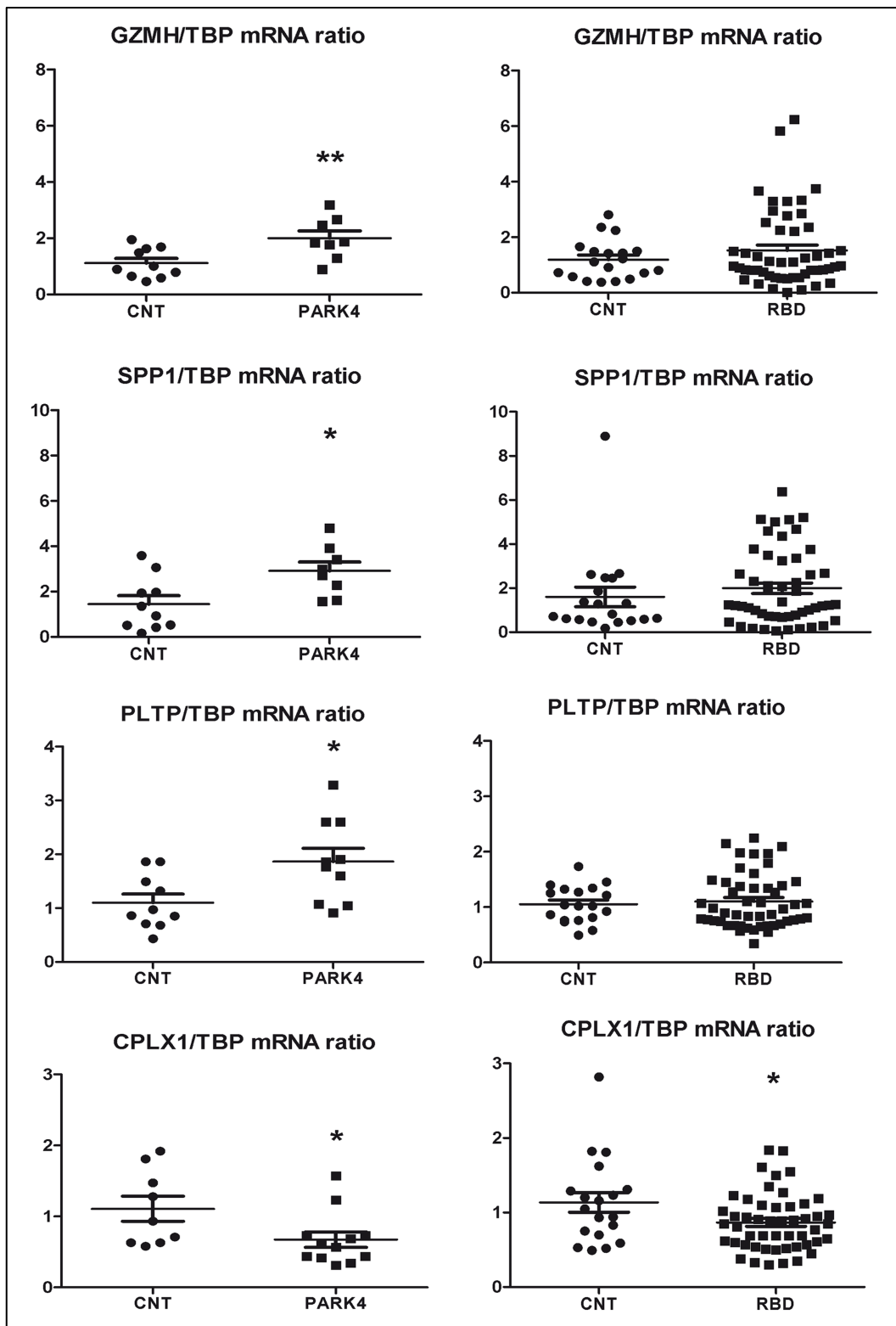

Figure 5.12. Scatter plots representing the mRNA expression levels of the three selected genes from RNAseq data and CPLX1 in PARK4 and RBD. Statistical significance is illustrated by an asterisk.

5.7. Validation of The Previously Reported PD Biomarkers

The previously reported PD biomarkers were validated in the PARK4 family and were further analyzed in RBD if they showed significant results. ST13 and SPP1 validation results were shown in previous sections (Figures 5.6 and 5.11). The two very recently reported PD biomarkers, HNF4A and PTBP1 were also investigated in the PARK4 family and did not show any significant alteration in mRNA expression levels (Santiago and Potashkin, 2015) (Figure 5.13).

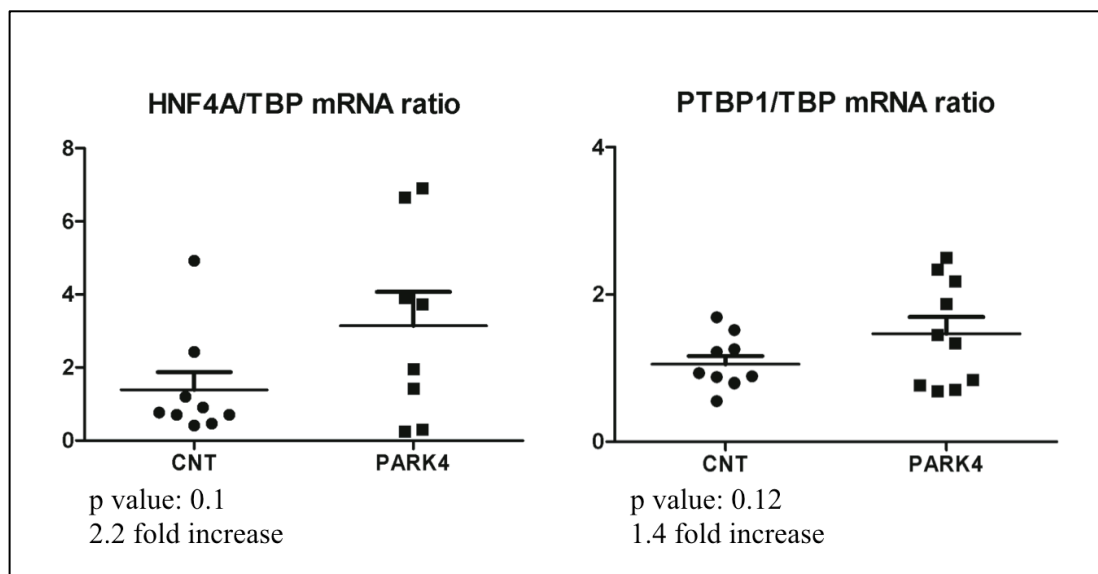

Figure 5.13. Scatter plots representing the mRNA expression levels of the previously reported PD biomarkers HNF4A and PTBP1.

5.8. Rep1 Analyses in German IPD and RLS cohorts

Rep1 dinucleotide repeat expansions in the promoter region of *SNCA* is known to have an effect on the expression and found to be associated with IPD, as described in the Introduction chapter. Rep1 regions of 510 IPD, 258 RLS and 235 CNT subjects from Germany were amplified with PCR, and genotypes were determined using GeneScan analysis (Figure 5.14).

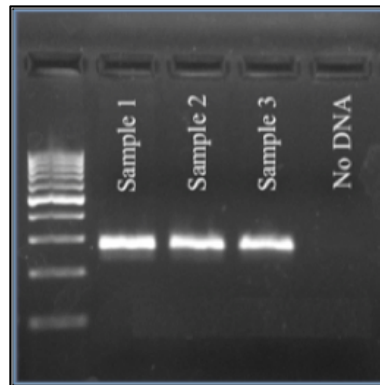

Figure 5.14. PCR amplification of Rep1 region detected between 265-271 bp.

Repeat regions are prone to give multiple peaks in GeneScan analysis, thus, genotyping of these regions should be analyzed cautiously. For the Rep1 genotyping, the first highest peak was considered as the first allele and the following significant peak was accepted as the second allele. Any significant peak was considered as a shoulder, if both alleles of an individual had the similar shoulder patterns (Figure 5.15). The four known variants (allele -1 with 265 bp, allele 0 with 267 bp, allele 1 with 269 bp, and allele 2 with 271 bp) were designated according to the nomenclature in a previous study of Caucasian populations (Xia *et al.*, 1996).

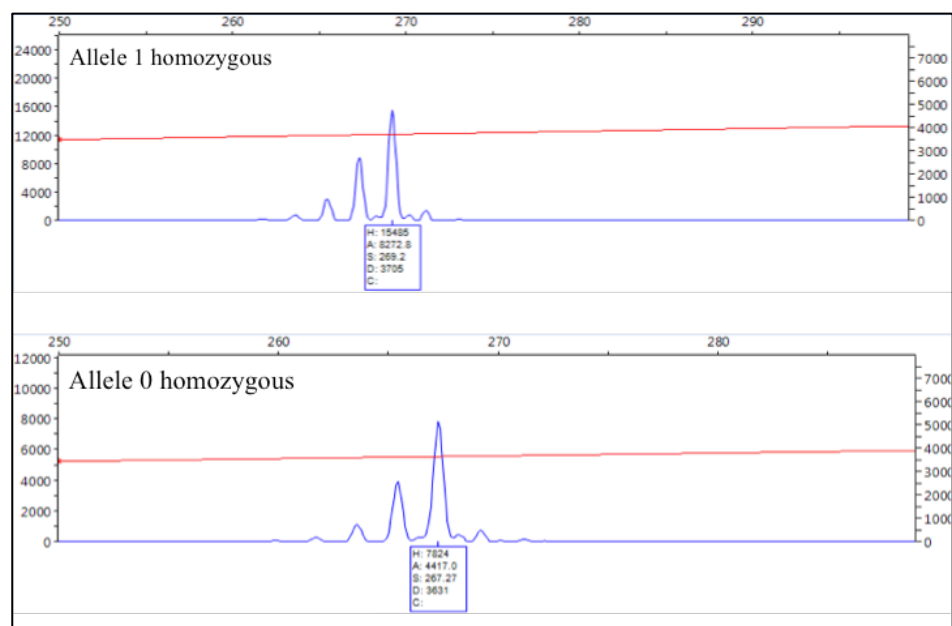

Figure 5.15. Representative genescan results of Rep1 genotypes.

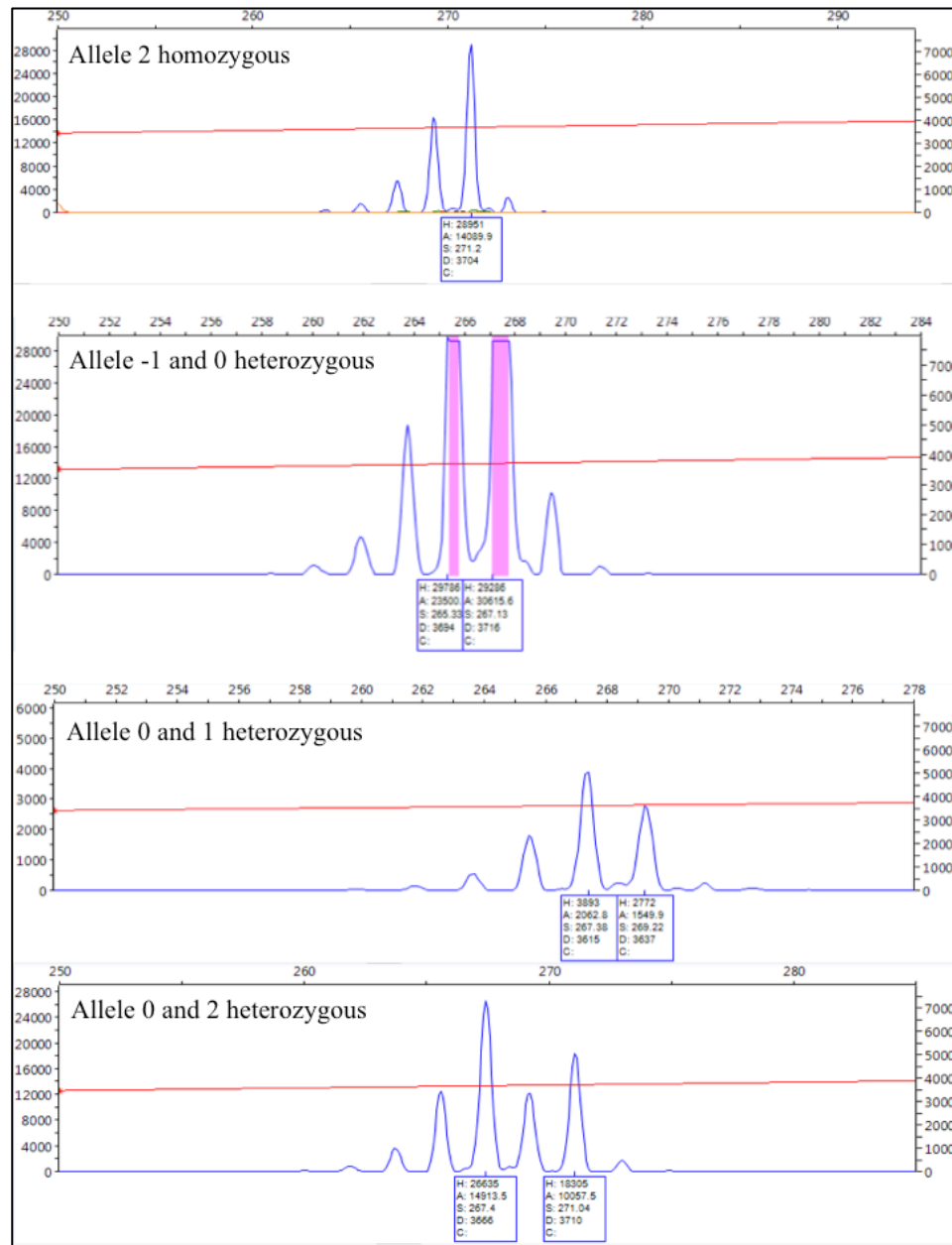

Figure 5.15. Representative genescan results of Rep1 genotypes (cont.).

The Rep1 allele 2 was not found to be associated with our IPD cohort. However, interestingly, the frequency of the Rep1 allele 2 was reduced significantly (p value: 0.016) in the RLS cohort; being 5.6 % (29/516) in RLS and 9.3 % (44/470) in CNT. Number of patients with each genotype is summarized in Table 5.2.

Table 5.2. Genotype matrices for RLS patients and CNTs.

Cohorts	RLS				CNT			
SNCA Rep1 Allele	-1	0	1	2	-1	0	1	2
-1	0	1	0	0	0	1	0	0
0		17	94	7		13	94	10
1			118	20			86	28
2				1				3

The percentage of each allele within the total allele number in CNT versus RLS is shown in Figure 5.16. This finding of Rep1 allele 2, being significantly reduced in RLS, was published, DOI 10.1007/s10048-014-0407-z (Lahut *et al.*, 2014).

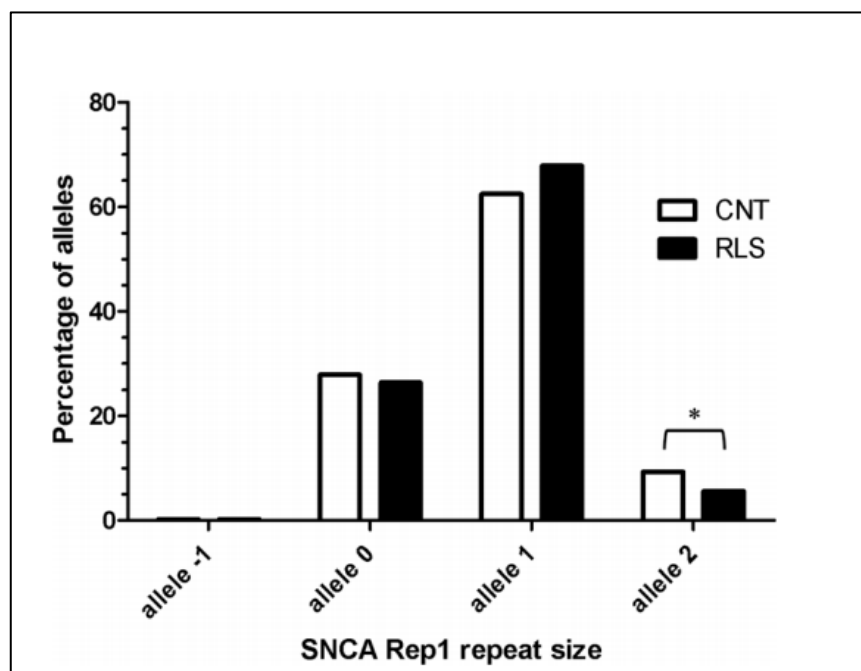

Figure 5.16. Allele frequency of Rep1 size is shown in percentage. Significance at the p value < 0.05 threshold is illustrated by an asterisk.

5.9. Effects of WWP2 on SNCA

The WW Domain Containing E3 Ubiquitin Protein Ligase (*WWP2*) was another gene that showed a significant upregulation in the previously mentioned mice, overexpressing human A53T-SNCA in nigrostriatal dopaminergic neurons transcriptome data (Kurz *et al.*, 2010). *WWP2* was suspected to be the ubiquitin ligase for SNCA, thus, was subjected to further analyses.

5.9.1. WWP2 as Blood Biomarker for PD

The *WWP2* mRNA expression level was tested in PARK4 and RBD, and no significant change in mRNA expression was observed. However, interestingly *WWP2* mRNA seemed to mimic SNCA expression profiles in both cohorts (Figure 5.17).

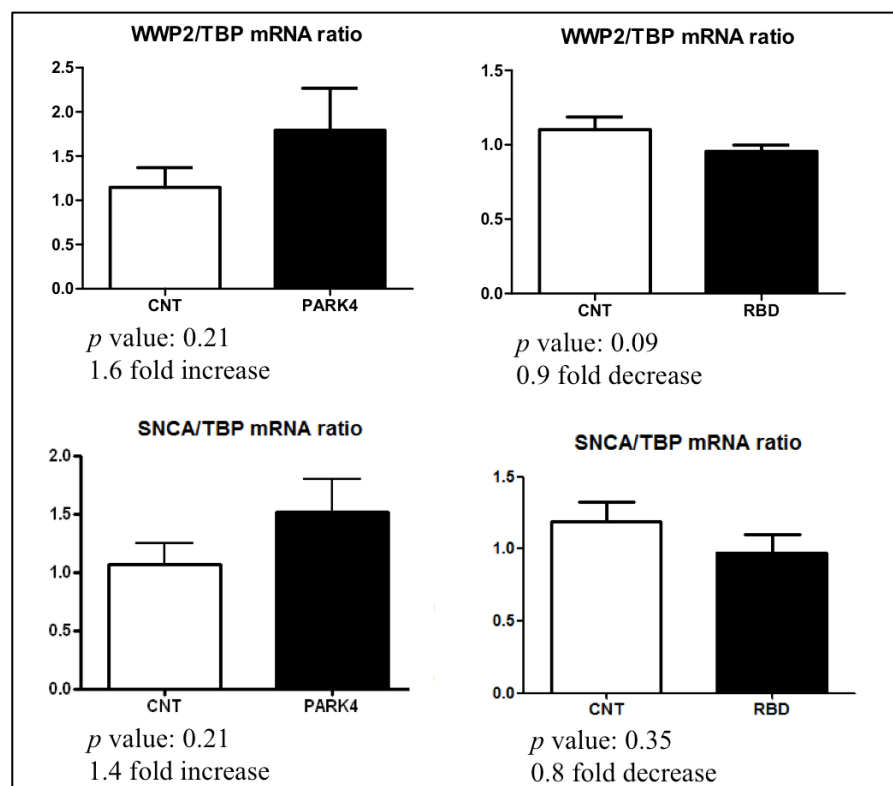

Figure 5.17. WWP2 mRNA expression levels in comparison to SNCA mRNA levels in PARK4 and RBD cohorts.

The RBD cohort (CNTs not included) was further sub grouped according to their SNCA expression levels into (i) individuals with normal expression levels of SNCA (SNCA-nrml) and (ii) individuals with SNCA elevated levels (SNCA-elvd). The WWP2 mRNA level was once more analyzed in these subgroups of RBD patients. Results showed no significant value, however the WWP2 level increased this time in the SNCA-elvd individuals of RBD (Figure 5.17). The statistical significance in the SNCA fold-change between SNCA-nrml and SNCA-elvd demonstrates the successful subgrouping performed within RBD.

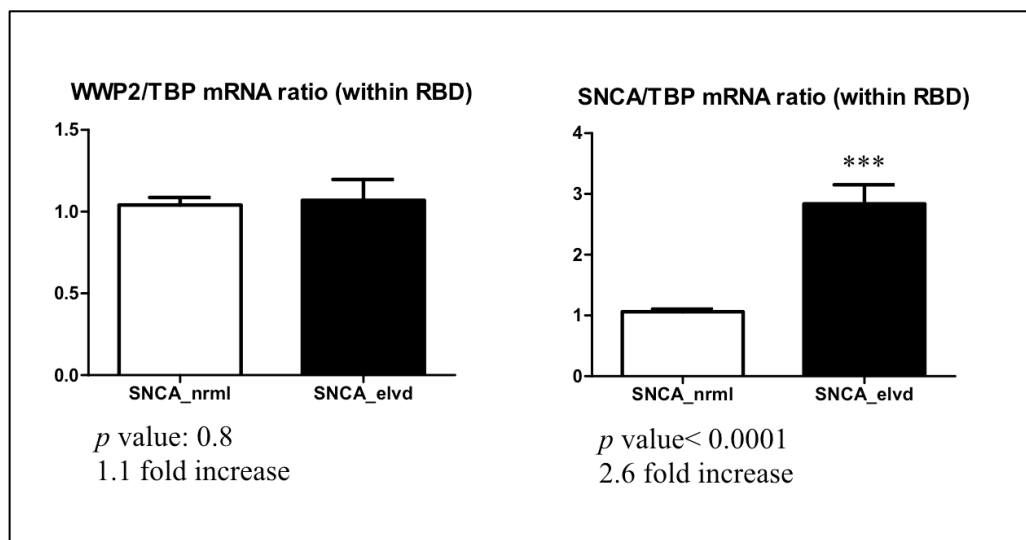

Figure 5.18. WWP2 mRNA expression levels in comparison to SNCA mRNA levels in SNCA-nrml and SNCA-elvd subgroups of RBD individuals. Statistical significance is illustrated by an asterisk.

5.9.2. Transfection of HeLa Cells

HeLa cells were used in order to observe cell responses to double transfections with *WWP2*, *SNCA*-WT, *SNCA*-A53T inserted plasmids (Table 5.3).

Table 5.3. List of plasmids used for single and double transfections and their abbreviations used in result figures.

Transfection	Abbreviation
pcDNA3.1-Entry Vector	D
pcDNA3.1- <i>SNCA</i> -WT	S
cDNA3.1- <i>SNCA</i> -A53T	A
pCMV6-Entry Vector	P
pCMV6- <i>WWP2</i>	W
pCMV6-Entry Vector + pcDNA3.1-Entry Vector	PD
pCMV6-Entry Vector + pcDNA3.1- <i>SNCA</i> -WT	PS
pCMV6-Entry Vector + cDNA3.1- <i>SNCA</i> -A53T	PA
pcDNA3.1-Entry Vector + pCMV6- <i>WWP2</i>	DW
pCMV6- <i>WWP2</i> + pcDNA3.1- <i>SNCA</i> -WT	WS
pCMV6- <i>WWP2</i> + cDNA3.1- <i>SNCA</i> -A53T	WA
No treatment (wild type)	WT

RNA and protein were isolated from each well simultaneously after 48 hours of transfection. Transfection efficiency was directly tested by qRT-PCR with Taqman assays specific to *WWP2* and *SNCA* cDNAs, while analyzing the mRNA expression levels of the cells. The preliminary results of the cell culture experiments demonstrated that, both double and single transfections of the HeLa cells were successful, however transfection profiles showed devastating variations for each transfection set (Figure 5.19).

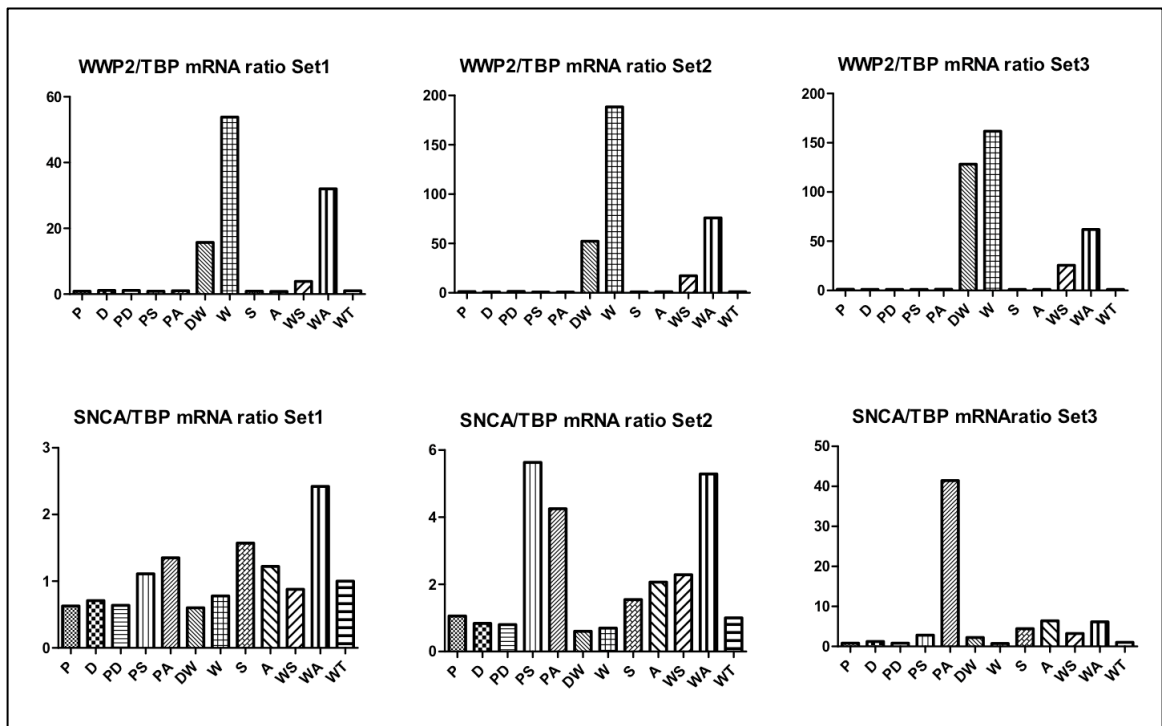

Figure 5.19. mRNA expression levels of WWP2 and SNCA (both *SNCA*-WT and *SNCA*-A53T transcripts are targeted with the same Taqman assay) in single and double transfected HeLa cells. Variations in three different experiment sets are compared.

In order to obtain significant and meaningful results from WB analyses of the transfected HeLa cells, at least three experiment sets with similar mRNA expressions are needed. Although, data with desired quality was yet absent, preliminary results of WB analysis suggested SNCA-WT, but not SNCA-A53T degradation in the presence of WWP2 protein in double transfected HeLa Cells (Figure 5.20).

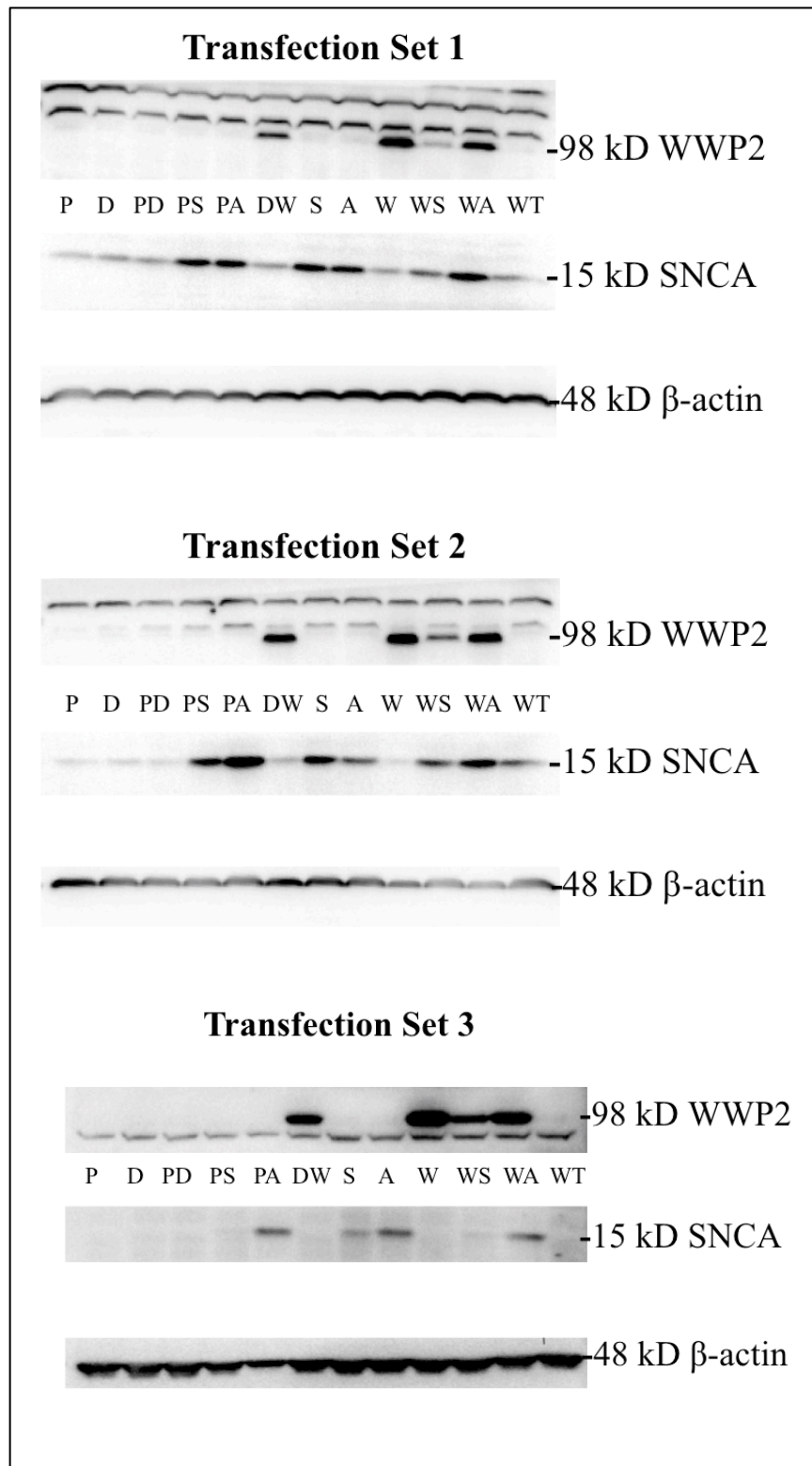

Figure 5.20. WB results of the transfected cells. Each lane is indicated with abbreviation IDs. SNCA level of WS appears to be less than in S, and WA does not seem to be affected from the presence of WWP2.

A summary of methods and results obtained in this thesis is shown in Figure 5.21.

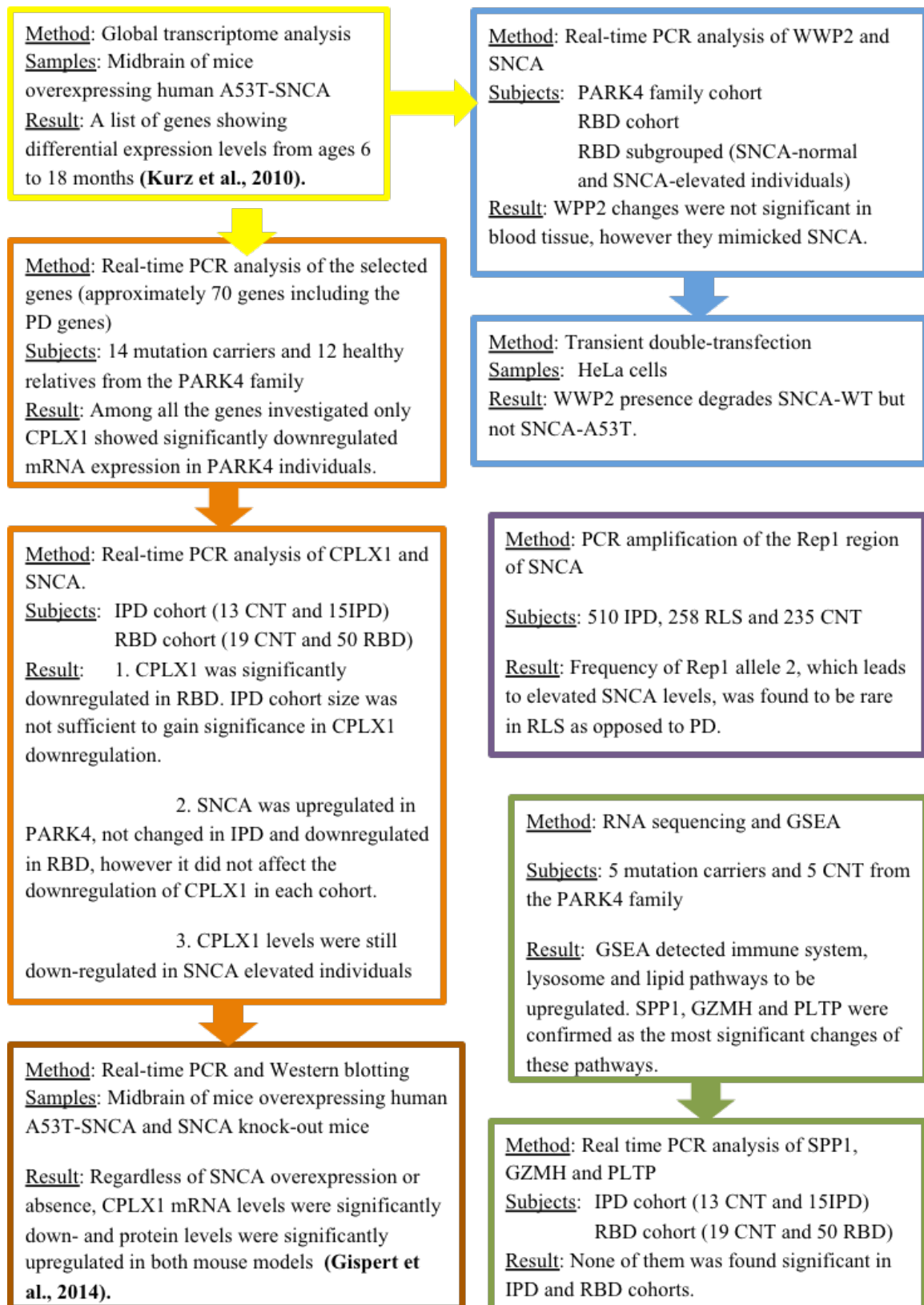

Figure 5.21. Summary of methods and results.

6. DISCUSSION

Biomarkers, reflecting the pathogenesis of Parkinson's disease, are greatly needed especially from easily accessible samples as is the case with blood samples. To date, the most extensively tested PD biomarkers are SNCA, DJ-1, amyloid- β , tau, uric acid and glutathione, and they are generally studied in cerebrospinal fluids of PD patients (Wang *et al.*, 2013). However, none of these or the recently identified markers deriving from the '-omics' technologies, completely fulfill the biomarker criteria defined in the Introduction chapter, and none has given consistent significant results in different PD cohorts.

This study reports, (i) an exceptionally large PD family, the PARK4 family, with a great advantage for biomarker analysis with several presymptomatic individuals, (ii) a novel gene in PD, CPLX1, as the best molecular biomarker identified in the literature, (iii) the longest size variant (allele 2) of the Rep1 region within the *SNCA* promoter to have significantly decreased frequency in restless leg syndrome and finally (iv) WWP2 to be the possible ubiquitin ligase for SNCA protein.

6.1. Importance of The PARK4 Family

PD genetics studies accelerated 25 years ago after the characterization of a large Italian family with the PARK1 mutation and the following publications revealed the heterogenic nature of the disease (Polymeropoulos *et al.*, 1997). Although the presymptomatic PARK1 individuals of the Italian Contursi family made the detailed study of human synucleinopathies and PD possible, the Contursi family was unwilling to give consent for any further analyses, until a cure for their disease was found.

Today, the identification and cooperativity of the Turkish PARK4 family pave the ways for systematic investigation of presymptomatic PD patients and make possible further studies of synucleinopathies in humans, such as brain imaging and sleep behaviors. The PARK4 family in Turkey, the second largest PD pedigree identified after the Contursi

family with sufficient numbers of subjects for statistical analyses, provides a homogenous human study cohort for the above listed analyses and many others (Figure 5.1).

6.2. CPLX1 in Parkinson's Disease

6.2.1. Function of Complexins

This thesis proposes a possible role for CPLX1 in PD progression, while representing its consistent mRNA downregulation in PD patients and models, in addition to its protein upregulation in PD models. Although the possible effect of this novel gene on disease mechanism should be further investigated in detail, the general function of the complexin proteins are very supportive of this hypothesis. Dysregulation of vesicle cycling pathway is one of the possible mechanisms underlying PD pathogenesis, and complexins are small soluble proteins that bind to SNARE complexes which in turn bring a synaptic vesicle and the cell membrane together and are critical for membrane fusion.

CPLX1 is a 134 aa, 15 kDa protein that is generally unstructured in solution, however, it forms a central α -helix that binds to SNARE complex. The central helix is crucial for both activating and inhibiting roles of CPLX1 on SNARE complex. The C-terminus of the protein also has both activating and inhibiting functions. The accessory helix, upstream of the central helix, has inhibitory function on SNARE complexes and the N-terminus of the protein releases the inhibitory effect of the accessory helix and thus, has an activating function (Figure 6.1 A) (Trimbuch *et al.*, 2014). These similarities in terms of function and structure of CPLX1 with the most important gene of PD, SNCA, may support the importance of CPLX1 in PD.

In neuronal cells the exocytosis of neurotransmitters is the fundamental mechanism for the transfer of information. Complexins play activating and inhibitory roles on SNARE complexes and the tight regulation of neurotransmitter release by exocytosis critically depends on them (McMahon *et al.*, 1995). Although not validated yet, the activating function of complexins on SNARE complex formation is proposed to be the stabilization of the complex (Chen *et al.*, 2002). The first model suggested for SNARE complex

stabilization is binding of the complexin C-terminal to membrane phospholipids (Seiler *et al.*, 2009). In the second model, the interaction of complexin N-terminus with the C-terminus of the SNARE complex, stabilizes the SNARE complex (Xue *et al.*, 2010). The inhibitory roles of complexins have attracted more attention, since several reports suggested that complexins prevent the Ca^{+2} -dependent exocytosis only before the Ca^{+2} influx (Reim *et al.*, 2001, Yang *et al.*, 2013). After Ca^{+2} influx, a protein called synaptotagmin-1 detaches complexin from the SNARE complex and thus release the inhibitory function, when it is bound to Ca^{+2} (Roggero *et al.*, 2007). However, interestingly, CPLX1 is not fully displaced by the Ca^{+2} -bound synaptotagmin-1 and there is a competition between these two proteins for binding to the SNARE complex on membranes (Xu *et al.*, 2013). Reported models of the inhibitory function of the accessory helix of complexin are shown in Figure 6.1 B, C and D. In all three models the accessory helix prevents the assembly of the C-terminus of SNARE complex, either by inserting into the complex (Figure 6.1 B), or binding to a specific SNARE complex component (synaptobrevin) (Figure 6.1 C), or by electrostatic repulsion with both, vesicle and cell membranes (Figure 6.1 D) (Trimbuch *et al.*, 2014). Elevated levels of CPLX1, as shown in this thesis, may cause defects in the regulation of neurotransmitter release and thus, favor the degeneration of the dopaminergic neurons. On the other hand, the defects in the neurotransmitter release mechanism may also lead to elevated levels of CPLX1 as a response to the disrupted mechanism.

6.2.2. Possible Mechanism in Parkinson's Disease

Function of CPLX1, the only consistent molecular biomarker identified in distinct PD cohorts, further supports the idea of presynaptic dysfunctions in the vesicle control machinery to be the common pathway leading to PD. As described in the Introduction chapter, SNCA, the most important protein in PD pathogenesis, enhances the SNARE complex formation by binding and acting as a chaperone for synaptobrevin, however this effect reversens when there is excess amount of SNCA binding to synaptobrevin (Sudhof and Rizo, 2011). The CPLX1 accessory helix also has a possible binding to synaptobrevin and through this binding it inhibits the SNARE complex formation (Trimbuch *et al.*, 2014). In addition CPLX1 competes with Ca^{+2} -bound synaptotagmin-1 for SNARE complex

binding and prevents it from releasing the inhibition caused by complexins. This study reports CPLX1 mRNA levels to be significantly downregulated in PD patients and protein levels to be significantly upregulated in PD mouse models, regardless from the SNCA levels (Figures 5.10 and 5.11). Thus, a possible common pathogenic pathway of CPLX1 in PD may be due to the elevated CPLX1 levels increasing the tendency to inhibitory roles on SNARE complex formation, inhibiting the neurotransmitter release from neurons. The findings presented jointly provides enough evidence for this hypothesis to be worth further investigating in mouse mutants and neurotoxic models.

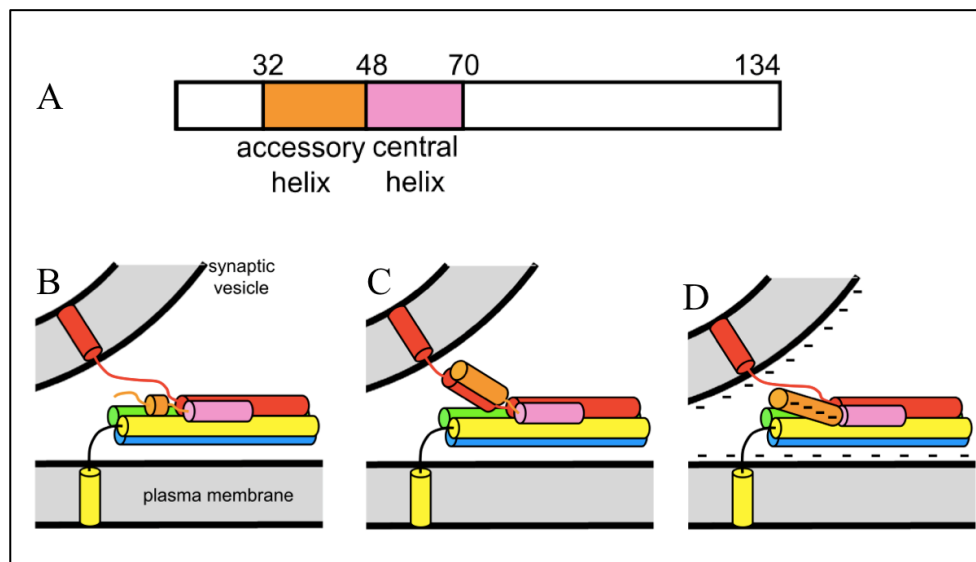

Figure 6.1. Models of complexin structure and function. (A) Domain diagram of complexin proteins. (B), (C) and (D) Models of complexin inhibitory function of the accessory helix on SNARE complexes (adopted from Trimbuch *et al.*, 2014).

6.2.3. CPLX1 as a PD biomarker

Risk diagnosis of a complex disease like PD is unlikely to be based on expression changes of a single molecular biomarker. However, together with the further validation of CPLX1 results in several other PD cohorts and the identification of some additional valid PD biomarkers, a blood expression signature for PD may be designed. Such a diagnostic tool would be similar to the clinical diagnosis of the disease itself, where not a single, but

only a combination of several clinical signs can lead to accurate PD diagnosis (Fahn, 2003).

In this study, the CPLX1 mRNA level was found to be significantly downregulated in mutation carriers of the PARK4 family and in REM sleep behavior disorder, representing the presymptomatic PD cohort, as compared to healthy controls. The CPLX1 mRNA level was also downregulated in IPD, however, was not found to be significant. This may be due to the small sample size of a heterogenous human cohort (13 CNT vs 15 IPD). On the other hand, the significance of a slight decrease in the mRNA level of CPLX1 in RBD, which was another heterogenous human cohort with sufficient subject numbers (19 CNT vs 50 RBD), strengthens the value of CPLX1 in PD. Although CPLX1 downregulation was first described in the PARK4 individuals with elevated levels of SNCA, it has been demonstrated in the framework of this thesis that CPLX1 downregulation is not a reaction to elevated SNCA levels, but the general course of PD (Figures 5.10 and 5.11). The quantification of the CPLX1 protein levels was not possible due to the abundance of hemoglobin, albumin and fibrinogen proteins in blood. Thus, further investigation of the CPLX1 protein in PD was investigated in mice models. These results represented the significant Cplx1 mRNA downregulation in parallel to a significant upregulation in protein levels and further confirmed that CPLX1 is affected in PD progression.

Additional evidence of CPLX1 being affected in PD progression, deriving from experiments performed by our collaborators, will be discussed in the following sections. All previous and upcoming CPLX1 findings represented in this thesis have been compiled in a report entitled “*Blood RNA biomarkers in prodromal PARK4 and REM sleep behavior disorder show role of complexin-1 loss for risk of Parkinson’s disease*” (Lahut and Gispert *et al.*, 2015, Submitted to PNAS).

6.2.4. CPLX1 in Human SH-SY5Y Cells

SH-SY5Y cells are widely used PD cell models with dopaminergic properties. To further evaluate the CPLX1 expression changes, human SH-SY5Y neuroblastoma cells

transiently overexpressing wild-type and A53T-mutant SNCA were used. Again, the downregulation of CPLX1 mRNA in parallel to accumulation of the protein was observed after 48 hours after transfection. Figure 6.2 (A-B) demonstrates the CPLX1 protein levels in empty vector (pcDNA)-transfected and transiently overexpressing wild-type (α -SynWT) and A53T-mutant SNCA (α -SynA53T) cells. In Figure 6.2 (C) the significant mRNA-fold change of CPLX1 between the control and transiently overexpressed cells are shown (Lahut and Gispert *et al.*, 2015, Submitted to PNAS). These data demonstrate that CPLX1 is affected early in neural cells and favor the CPLX1 upregulation to have an effect on PD progression, rather than being a response to the defects of the disease.

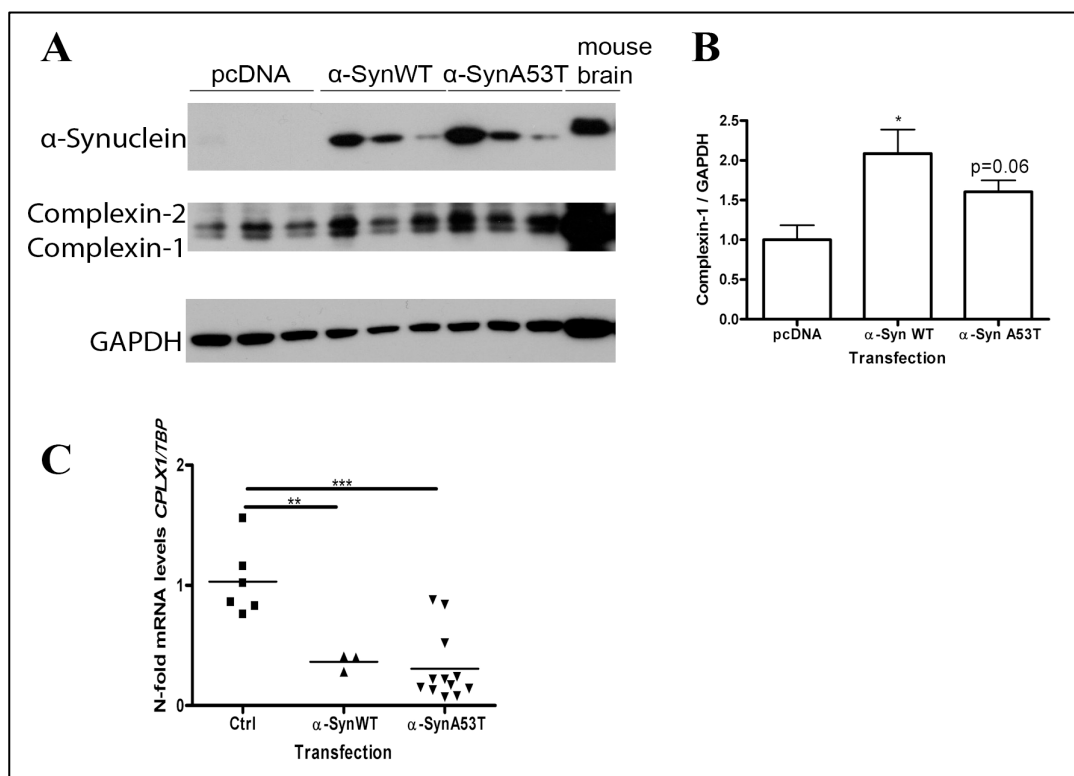

Figure 6.2. CPLX1 changes in protein and mRNA levels of transiently transfected human SH-SY5Y cells.

6.2.5. CPLX1 in PD Patient Brain

As mentioned before, CPLX1 levels could not be quantified in human blood, thus, were analyzed in mice. Levels of CPLX1 were found to be increased in midbrain tissue dissected from PD mouse models (Figure 5.11) (Gispert *et al.*, 2014). This finding raised

the question, whether CPLX1 aggregated within the Lewy bodies. Immunohistochemical analyses of PD patient midbrains showed CPLX1-stained aggregates in neurites and neuronal perikarya of PD patients (Figure 6.3 A-D). Further, double immunofluorescence analyses revealed colocalization of SNCA and CPLX1 (Figure 6.3 E-H). In Figure 6.3 (A-C), neurons in the substantia nigra exhibiting Lewy body-like structures stained with anti-complexin-1 (arrowheads) are shown. CPLX1 immunopositive Lewy neurite-like structure (asterisks) in the medulla at the level of the motor vagus nucleus is displayed in (D), and co-localization of SNCA (green) and CPLX1 (red) is presented in (E-H) (Lahut and Gispert *et al.*, 2015, Submitted to PNAS). These observations strengthen the implication of CPLX1 in PD pathology and show that CPLX1 is sequestered into Lewy bodies.

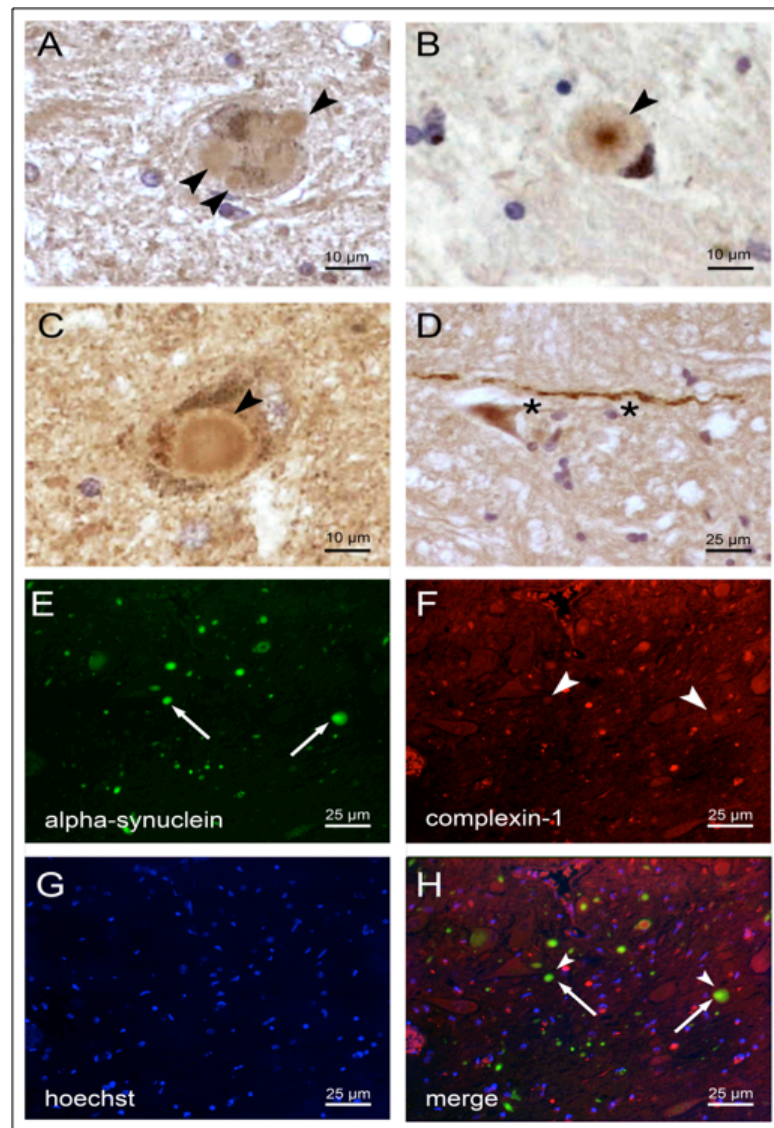

Figure 6.3. PD midbrain autopsies with CPLX1 cytoplasmic and neuritic aggregates.

6.2.6. *CPLX1* Variants as PD Risk Factor

Interestingly, the *CPLX1* gene is encoded within a PD risk haplotype on chromosome 4p16.3 identified with genome wide association studies (GWAS) meta-analyses (Lill *et al.*, 2012). In order to investigate the association of *CPLX1* variants with PD, 360 random IPD patients and 358 controls were studied regarding the SNPs in the 3'-UTR region of the gene. A significant association of the G allele of rs1794536 with PD risk was detected (Table 6.1) (Lahut and Gispert *et al.*, 2015, Submitted to PNAS). This finding suggests that *CPLX1* not only serves as a molecular biomarker for PD, but also modulates PD risk.

Table 6.1. *CPLX1* SNP rs1794536 G-allele is associated with PD risk.

Group	Genotypic frequencies (%)			Allelic frequencies (%)	
	GG	GT	TT	G	T
PD Patients (n = 360)	12 (3.333%)	116 (32.222%)	232 (64.444%)	140 (19.444%)	580 (80.556%)
Controls (n = 358)	5 (1.397%)	100 (27.933%)	253 (70.670%)	110 (15.363%)	606 (84.637%)
	$\chi^2 = 4.97$ P = 0.0833			$\chi^2 = 4.159$ P = 0.0414*	

6.2.7. Absence of *CPLX1* Upregulates SNCA Levels

Cplx1 knock-out mice display dystonia, shuffled walking and reduced novelty seeking, which are the characteristic signs of nigrostriatal dysfunction. Interestingly, these mice also display resting tremor, which is the diagnostic hallmark of PD in humans (Reim *et al.*, 200; Glyn *et al.*, 2005). Realizing the interesting features of *Cplx1* knock-out mice being reminiscent of PD, the loss-of-function mechanism of *cplx1* on PD susceptibility was further investigated. *SncA* mRNA and protein levels were significantly increased in the *Cplx1* null mice (1.3-1.5-fold) (Figure 6.4) (Lahut and Gispert *et al.*, 2015, Submitted to PNAS). Absence of complexins leads to severe impairments in the Ca⁺²-dependent exocytosis (Reim *et al.*, 2001, Yang *et al.*, 2013). These data provide evidence that *CPLX1*

affects SNCA expression levels, and this may be due to a feedback mechanism in the presynaptic vesicle cycling pathway.

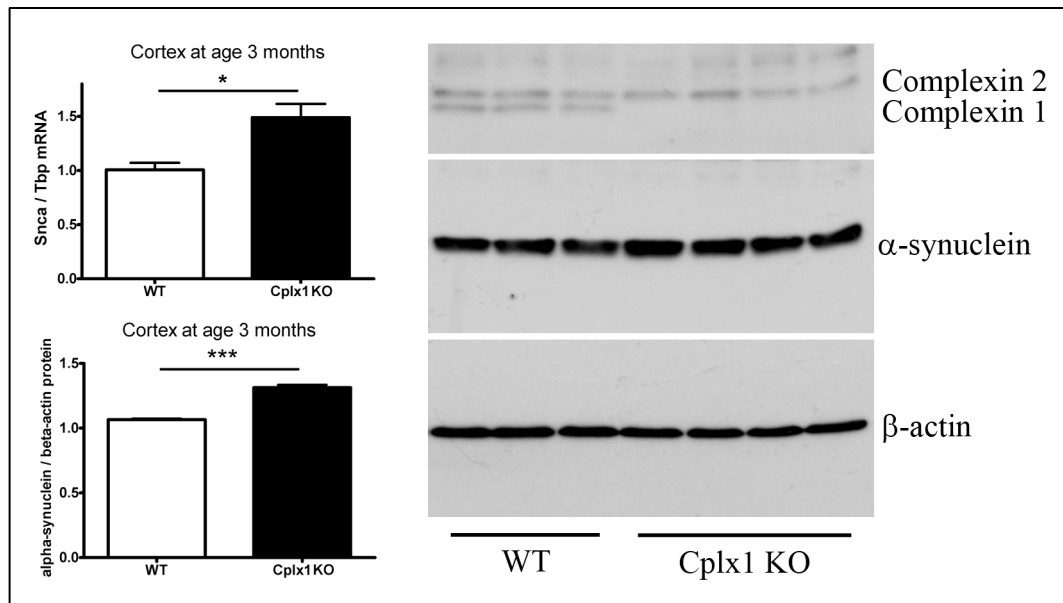

Figure 6.4. Elevated SNCA mRNA and protein levels in Cplx1 knock-out mice.

Eventually, this study proposes CPLX1 as an early biomarker and a risk factor for PD, besides, it encourages future studies to investigate the CPLX1 interactors and the presynaptic vesicle cycling pathway proteins for identification of additional PD biomarkers. In the long term, further investigations of CPLX1 in PD progression may be helpful in the identification of the valid pathogenic mechanism underlying the disease.

6.3. RNA Sequencing Analyses

As discussed earlier, the risk diagnosis of PD is unlikely to be based on a single molecular biomarker, however, with the identification of some additional valid PD biomarkers, a blood expression signature may be designed. In this direction, the global transcriptome analysis was performed and the pathway dysregulations were evaluated by gene set enrichment analysis bioinformatics. This method formulates a statistic to ensemble the genes in each gene-set. Thus, it can detect a pathway dysregulation in a

cohort, with increased statistical power, even if different genes of the same gene-set are affected in each individual of that cohort (<http://www.broadinstitute.org/gsea/index.jsp>). The immune system was the outstanding pathway upregulated in PARK4 samples, which is not surprising, since the role of innate immune responses in neurodegenerative processes in many CNS diseases is evident (Graeber and Streit, 2010, Hirsch and Hunot, 2009, Lucin and Wyss-Coray, 2009). Besides, the extracellular SNCA released from neuronal cells is reported to be an endogenous agonist for toll-like receptor 2 (TLR2), which activates inflammatory responses in microglia (Kim *et al.*, 2013). Additionally, the importance of the vesicle cycling pathway in PD was once more manifested by GSEA with the demonstration of the lipids, lipoproteins and for endocytosis pathways being upregulated in PARK4 individuals.

Further confirmation studies of these pathways identified SPP1 (from the immunity pathway), GZMH (from lysosome pathway) and PLTP (from lipid metabolism pathway). The results confirmed these genes as biomarkers only specific for PARK4 individuals, since they failed to distinguish between presymptomatic PD and healthy individuals. This finding may suggest SPP1, GZMH and PLTP to be possible molecular biomarkers only for synucleinopathies, however, their specificity and sensitivity should be further investigated.

6.4. Other Biomarkers of Parkinson's Disease

Neither of the previously identified molecular biomarkers ST13, HNF4A and PTBP1 were confirmed in PARK4 and presymptomatic PD, with the exception of SPP1. SPP1 was found significantly upregulated in PARK4, however it failed in distinguishing presymptomatic PD. Interestingly the only reason SPP1 failed to reach significance was a single control individual who had an extremely elevated level of SPP1 (Figure 5.12). The immune system may be affected from various environmental factors, thus may fail to provide a valid biomarker for disease diagnosis.

Apart from the molecular biomarkers, various cellular processes may also serve as disease biomarkers. Previous publications have reported a negative regulatory role of SNCA on alpha-granule release (Barbour *et al.*, 2008, Park *et al.*, 2002, Shin *et al.*, 2000).

Platelet function in two presymptomatic PARK4 mutation carriers and three age- and sex-matched first-degree healthy relatives were investigated. The presence of alpha-granules and lysosomes in the cell surface were diminished in PARK4 individuals when compared to their first-degree healthy relatives. Electron microscopy showed a central localization of the alpha-granules (Figure 6.5) (Lahut and Gispert *et al.*, 2015, Submitted to PNAS). The decrease in the platelet alpha granulation might serve as a biomarker for synucleinopathies, however its utility in IPD and presymptomatic PD should be further investigated.

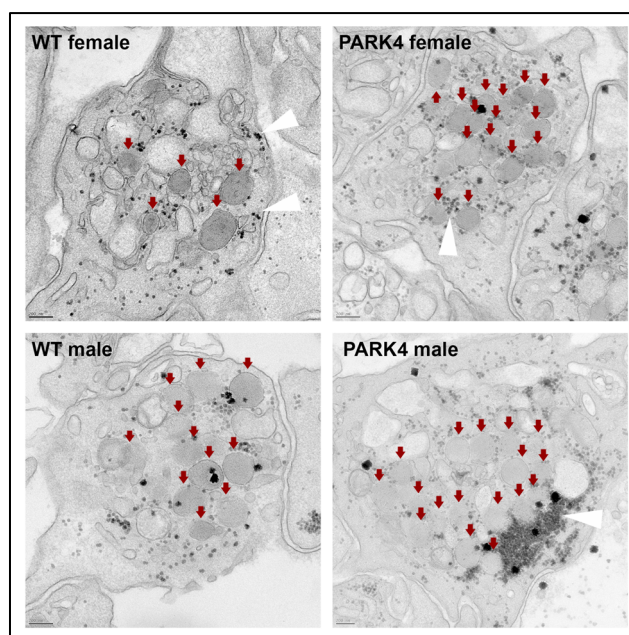

Figure 6.5. Electron microscopy of blood platelets after stimulus-triggered degranulation. Red arrows represent the alpha granules.

6.5. Rep1 Analyses in IPD and RLS

Rep 1 is thought to play a role in the control of *SNCA* expression and has been examined in several studies for a possible association with sporadic PD, rising conflicting results (Chiba-Falek and Nussbaum, 2001, Mellick *et al.*, 2005, Mizuta *et al.*, 2002, Spadafora *et al.*, 2003). In order to define individuals with Rep1 allele 2, thought to have elevated *SNCA* expression, and to test the association of allele 2 with PD, 510 IPD, 258 RLS and 235 CNT subjects were amplified for the Rep1 dinucleotide repeat region. Allele

2 was not found associated to PD in the IPD cohort, but interestingly, the frequency of allele 2 was significantly reduced in RLS patients, suggesting that the elevated *SNCA* levels due to Rep1 allele 2 are rare in RLS, as opposed to PD. Indeed, PD and RLS could be considered as opposite diseases in terms of clinical symptoms, regarding that PD is characterized by impaired initiation of spontaneous movements with striatal dopamine deficit, whereas RLS is a disease characterized by an unbearable urge to move the legs with increased striatal dopamine signaling (Trenkwalder and Paulus, 2010). On the other hand, they are both due to a dopaminergic dysfunction, thus they have the same effective treatment with dopaminergic drugs (Schrempf *et al.*, 2014).

This finding is of great importance, since there is no evidence of a common genetic variant in RLS yet. Preliminary genetic studies in RLS have identified a number of susceptibility regions based on GWAS, which need to be further investigated. The demonstration of allele 2 infrequency of the *SNCA* Rep1 region in RLS may indicate loss-of-function variants in *SNCA*, contributing to the disease.

6.6. *SNCA* Ubiquitination by WWP2

Although the *SNCA* protein level in neurons is fundamentally linked to neurodegeneration, up to date it remains unclear which critical ubiquitination enzymes protect against *SNCA* accumulation *in vivo*. The overexpression of a ubiquitin ligase, NEDD4 (neuronally-expressed developmentally down-regulated gene 4), is reported to target *SNCA* in human cell culture (Tofaris *et al.*, 2011). A following study shows that overexpression of Nedd4 (i) rescues the degenerative phenotype of *SNCA* in the *Drosophila* eye, (ii) prevents α -synuclein-induced locomotor defect in *Drosophila* brain and (iii) decreases the *SNCA*-induced dopaminergic cell loss in rat substantia nigra and reduces α -synuclein accumulation (Davies *et al.*, 2014).

Proteins prone to degradation are tagged with a ubiquitin chain by a catalytic process involving a ubiquitin-activating enzyme (E1), a ubiquitin conjugating enzyme (E2) and a ubiquitin ligase (E3) (Figure 6.6). The E3 enzymes regulate the substrate specificity and the type of ubiquitin linkages, which determine whether the protein is degraded by the

proteasome or the lysosome. Both proteasomes and lysosomes can degrade SNCA, however, research of lysosome degradation have become popular due to the implication of Nedd4 as a ubiquitin ligase for SNCA (Tofaris, 2012).

WWP2 is another HECT-type E3, like NEDD4, which was significantly upregulated between 6 to 18 months of mice overexpressing human A53T-SNCA (Figure 6.6). This period is when these mice have disease progression and start to show symptoms. On the basis of this finding, the WWP2 mRNA level was analyzed in blood samples of the PARK4 family and the RBD cohort. Although, the results were insignificant, the WWP2 level was found to mimic SNCA levels (Figure 5.17). WWP2 level was upregulated in PARK4 individuals with upregulated SNCA levels and was downregulated in RBD, which showed downregulated SNCA levels. Further subgrouping of the RBD individuals into SNCA elevated (SNCA-elvd) and SNCA normal (SNCA-nrml) individuals, showed increased WWP2 levels in the SNCA-elvd subgroup (Figure 5.18). The failure of WWP2 levels reaching significance in human blood tissue may be due to the short life span of the blood cells, disabling them from accumulating SNCA dimers and oligomers in long periods (Figure 5.5). Additional cell culture experiments suggested that WWP2 degraded SNCA-WT, but not SNCA-A53T in the double transfected HeLa cells (Figure 5.20).

Taken all together, the findings of the WWP2 level being upregulated in SNCA-overexpressing mice and human blood with the elevated SNCA levels, suggests WWP2 to be the ubiquitin ligase for SNCA *in vivo*. The previous publications on NEDD4 might have supported this hypothesis by overexpressing another HECT-type ubiquitin ligase (NEDD4), sharing a very similar activity with WWP2 in cell culture, *Drosophila* and rat, resulting in decreased SNCA pathology (Tofaris, 2012, Tofaris *et al.*, 2011). The vast majority of NEDD4 expressed in the above-mentioned studies might have substituted the activity of WWP2 on SNCA.

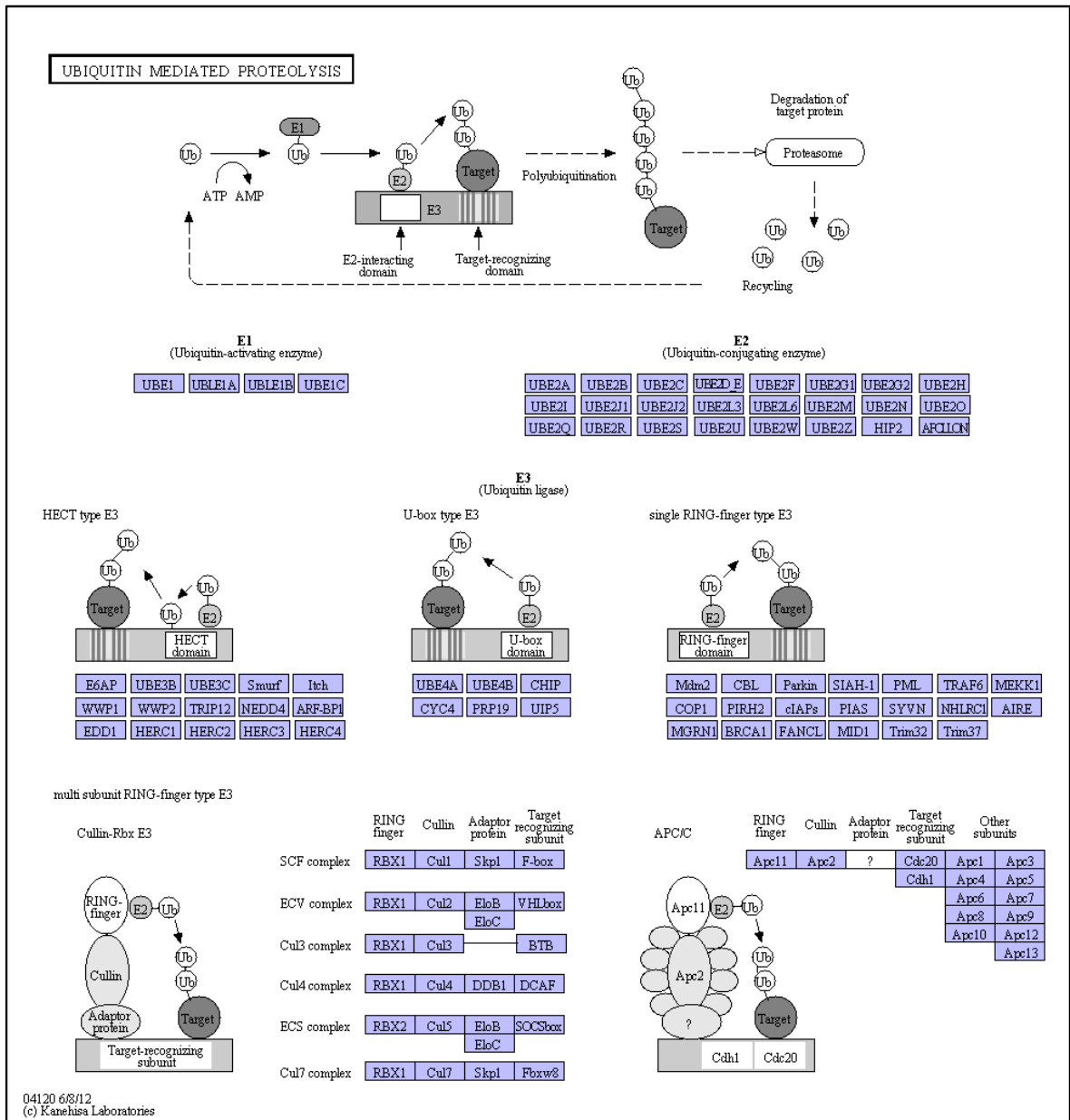

Figure 6.6. KEGG pathway map of ubiquitin-mediated proteolysis (http://www.genome.jp/kegg-bin/show_pathway?ggo04120).

The importance of this finding is based on the fact that the SNCA content in neurons is critical for the onset of neurodegeneration. The familial PARK4 cases show a strong gene-dosage effect, and Rep1 polymorphisms that increase SNCA expression are a risk factor for PD (Maraganore *et al.*, 2006, Ross *et al.*, 2008). Additionally, in animal studies, overexpression of SNCA leads to neurodegeneration and locomotor defects (Chung *et al.*, 2009a, Chung *et al.*, 2009b, Tofaris *et al.*, 2006), and these can be reversed

by switching off the transgene (Lim *et al.*, 2011). Conversely, knockout of α -synuclein in mice confers protection against certain toxins (Dauer *et al.*, 2002). Thus, promoting the degradation of SNCA and reducing its level in neurons could serve as a novel neuroprotective strategy for PD therapeutics, and such a goal can only be reached by identification of the components of SNCA degradation *in vivo*.

7. CONCLUSION

In conclusion, this study reports a possible role of a novel gene, *complexin-1*, in PD pathology and identifies it as an early molecular biomarker and a risk factor for PD. The results obtained, highlight the importance of the vesicle cycling pathway in PD. They further encourage future investigations of CPLX1 interactors and the presynaptic vesicle cycling pathway proteins in order to identify additional disease biomarkers.

The second part of this study indicates a genetic susceptibility to RLS with the identification of the *SNCA* Rep1 region allele2, being less frequent in RLS patients when compared to PD patients. This antilogy between RLS and PD, that can be considered as opposite diseases with respect to their clinical features, is quite attractive and may lead to a possible identification of future genetic variants contributing to RLS.

Lastly, this study suggests a possible role of WWP2, instead of the previously identified NEDD4, for SNCA degradation *in vivo*. By this, the thesis promotes the future SNCA-degradation studies as a novel neuroprotective strategy for PD therapeutics.

APPENDIX A: SUPPLEMENTARY TABLES

Table S1. The upregulated pathways in PARK4, detected with GSEA bioinformatics.

GeneSet	Enrichment Score (ES)	Normalized Enrichment Score (NES)	Nominal p-value	FDR q-value	FWER p-Value
Reactome cytokine signaling in immune system	0.26554778	4.832001	0.0	0.0	0.0
Reactome adaptive immune system	0.18044785	4.5287533	0.0	0.0	0.0
Reactome hemostasis	0.2041919	4.4180493	0.0	0.0	0.0
KEGG lysosome	0.3472282	4.340293	0.0	0.0	0.0
Reactome platelet activation signaling and aggregation	0.2664414	4.085812	0.0	0.0	0.0
Reactome innate immune system	0.22265689	4.0507555	0.0	0.0	0.0
KEGG endocytosis	0.27330062	3.9454603	0.0	0.0	0.0
KEGG Toll-like receptor signaling pathway	0.29090896	3.3466032	0.0	0.0	0.0
Reactome metabolism of lipids and lipoproteins	0.14163479	3.3185751	0.0	0.0	0.0
Extracellular region	0.14901806	2.909486	0.0	0.0	0.0

APPENDIX B: INFORMED WRITTEN CONSENT

BİYOLOJİK ARAŞTIRMA İÇİN BİLGİ FORMU

Proje Yürütücüsü: Prof. Dr. A. Nazlı Başak
Boğaziçi Üniversitesi
Tel: 212- 359 66 79 / 359 72 98

Nörolog Hekim: Doç. Dr. Hülya Tireli
Haydarpaşa Numune Hastanesi
Tel: 216- 414 45 02 / 1422

Parkinson hastalığı, dünyada 4.000.000'dan fazla kişiyi etkileyen, sık rastlanan bir nörolojik hastalıktır. Kadın ve erkeklerde görülme oranı aynıdır; 65 yaş üzerindeki her 100 kişiden biri Parkinson hastasıdır. Parkinson yavaş ilerleyen bir hastalıktır; hayatı etkilediği halde, yaşamı tehdit etmez; beyinde dopamin adlı bir maddenin sentezlendiği sinir hücrelerinin kaybı sonucu ortaya çıkar. Parkinson'un ilk belirtileri beyindeki dopamin düzeyi normalin % 20 altına düştüğü zaman görülür. Parkinson sadece yaşlıların hastalığı değildir. Genellikle ortalama 60 yaşında tanı konulduğu halde, Parkinson'lu her yirmi kişiden birinde ilk bulgular 40 yaşından önce görülmektedir. 21-40 yaş arasındaki hastalar, "Erken Başlangıçlı Parkinson Hastalığı" tanısı alırlar.

Günümüzde Parkinson ve benzeri beyin hastalıkları ile ilgili çalışmalar, özellikle de genetik çalışmalar büyük hız kazanmıştır. Genetik çalışmaların başında, hastalığa neden olan aday genlerde görülen genetik değişikliklerin (mutasyonların) test edilmeleri gelir. Parkinson hastalığına neden olan genlerin bulunması ve özelliklerinin anlaşılması, bu hastalığa yol açan mekanizmaların tanınması açısından büyük önem taşımaktadır.

Bugüne kadar henüz kesin tedavisi olmayan Parkinson ve benzeri nörodejeneratif hastalıklarda erken tanı büyük önem taşımaktadır. Bunun için hastalığın moleküler yapısının, hastalığa neden olan mutasyon ve yolakların anlaşılması ve de hastalık tanısını kolaylaştıracak biyokimyasal markörlerin geliştirilmesi kesin tedaviler açısından son derece değerlidir.

Sizden bu çalışmaya katılmanızı istememizin nedeni, sizde veya ailenizde bir/birçok olguda Parkinson hastalığının görülüyor olmasıdır. Çalışmaya katılmanız tamamen isteğinize bağlıdır. Sizden ücret talep edilmeyecektir ve size herhangi bir ödeme yapılmayacaktır. Araştırmaya katılmayı kabul ettiğiniz takdirde sizden on mililitre kan örneği alınacaktır. Yapacağımız araştırmanın size bir risk getirmesi beklenmemektedir. Kan aldırmanın genelde hiçbir zararı olmamasına karşın, nadiren çok az kanama ve morarmaya yol açabilir.

Çalışmaya kan verilerek gösterilecek gerekli toplumsal duyarlılık, çalışma açısından büyük önem taşımaktadır. Sizden aşağıda imzalamanızı istediğimiz onay formunda bu projeye katılımcı olarak elde ettiğiniz haklar aşağıda özetlenmiştir.

1. Bu araştırma projesinin sonuçları kişisel olarak kimliğimi belirleyecek şekilde yayımlanmayacağı tarafıma bildirilmiştir. Bu proje kapsamında kanuni bir zorunluluktur.
2. Önerilen araştırma yöntemlerinin detayları bana açıkca anlatıldı.
3. Bu projeye katılımımın bana yarar sağlamaya yönelik olmadığı bana açıklandı. Bu araştırmanın amacının ileride tıbbi müdahalelerin kalitesini artırılmasına yönelik olduğunu anlıyorum.
4. Kendimim/çocuğumun katılımı için verdiğim onaydan her hangi bir aşamada bir açıklama yapmadan vazgeçebileceğimin farkındayım. Bunun benim/çocuğum için gereken tıbbi müdahalede bir olumsuzluk yaratmayacağını biliyorum. Bu durumda genetik materyal, potansiyel sonuçlar hakkında bilgi ve kinik veriler ortadan kaldırılacaktır.
5. Bu projenin Helsinki deklarasyonunda tarif edilen etik kurallara bağlı olduğunu açıkca biliyorum.
6. Bu projenin Boğaziçi Üniversitesi İnsan Araştırmaları Kurumsal Komisyonu tarafından gözden geçirildiğini ve onaylandığını açıkca biliyorum.
7. Bu dökümanın bir kopyasını aldım.

BİLİMSEL BİR ÇALIŞMAYA KATILIM İÇİN ONAM FORMU

Hasta Kodu: _____

Bağlantı Adresi: _____

Proje yürütücüsü: Prof. Dr. A. Nazlı Başak

Proje başlığı: Parkinson Hastalığının Moleküler Biyolojisi

Araştırmacılar: Doç. Dr. Hülya Tireli, Nöroloji Kliniği, Haydarpaşa Numune Hastanesi

Prof. Dr. Georg Auburger, Nöroloji Kliniği, Frankfurt Üniversitesi,

Suna Lahut, Özgür Ömür, Moleküler Biyoloji ve Genetik, Boğaziçi Üniversitesi

I. Proje onayı ile ilgili

Ben _____ Dr. Hülya Tireli/ Dr. A. Nazlı Başak tarafından bana açıklanan yukarıda adı geçen çalışmaya dahil olmak için onay veriyorum.

- Bilgilendirme yazısında açıklananların hepsini anladım ve bu proje çerçevesinde benden istenilenleri biliyorum.
- Araştırma sonuçlarının benim/çocuğum için şahsi sonuçları olabileceğini anlıyorum.
- Bu araştırma sonuçlarının sadece istediğim taktirde bana verileceğini anlıyorum.
- Sonuçları bilmemeye hakkım olduğunu anlıyorum.
- Araştırmacıların bütün şahsi bilgilerimi gizlilikle kullanmaya ve değerlendirmeye zorunlu olduklarını anlıyorum.
- Araştırma sonuçlarının herhangi bir şekilde yayınlanması durumunda kimlik bilgilerimin belirlenemeyeceğini anlıyorum.
- Araştırmaya katılmaktan vazgeçmem veya araştırmadan çekilmem durumunda benim /çocuklarımın tedavi almasının etkilenmeyeceğini anlıyorum.
- Bu durumda, genetik materyalin, olası sonuçlar hakkında bilginin ve klinik verilerin imha edileceğini biliyorum.

- Araştırma sonuçlarının açıklanmasından sonra genetik danışmanlık verileceğini anlıyorum.
- Araştırma sonuçlarının bana ve aileme doğrudan bir faydasının olmayabileceğini, ama bundan sonraki nesiller için önemli olabileceğini anlıyorum.
- Soru sorma fırsatım oldu ve verilen cevaplardan tatmin oldum.

II. Çalışmanın uygulaması ile ilgili (uygun bölümü işaretleyiniz):

___Kan örneği sadece bu proje çerçevesinde kullanılmak üzere alınacak, bir kısmı yurtdışında yürütülebilecek.

___Kan örneği bu proje ve Etik kurul onayı alınmış gelecekteki projeler için alınacak. Kan örneğim gelecekteki bir projede bana sorulmadan kullanılmayacağı konusunda bilgilendirildim. Çalışmaların bir kısmı yurtdışında yürütülebilecek.

___Kan örneği bu proje ve Etik kurul onayı alınmış gelecekteki projeler için alınacak. Kan örneğim gelecekteki bir projede bana sorulmadan kullanılabilirliği konusunda bilgilendirildim. Çalışmaların bir kısmı yurtdışında yürütülebilecek.

___Proje sonuçlarının beni/çocuğumu ilgilendiren sonuçları hakkında bilgilendirilmek istiyorum. Bu kapsamda genetik danışmanlık verileceğini anlıyorum.

Katılımcı/Veli veya Vasinin adı, soyadı:

İmzası:

Tarih:

Bu formu imzalamadan önce, çalışmayla ilgili sorularınız varsa lütfen sorun. Daha sonra sorunuz olursa Dr. A. Nazlı Başak'a ve Dr. Hülya Tireli'ye (telefon numaraları formda belirtilmiştir) sorabilirsiniz.

Araştırma projesini yukarıda adı geçen katılımcıya anlattım, katılımcının projenin amacını, çerçevesini ve olası sonuçlarını anladığını düşünüyorum.

Açıklamayı yapan doktorun adı, soyadı:

İmzası:

Tarih:

APPENDIX C: PUBLICATIONS

The distinct genetic pattern of ALS in Turkey and novel mutations.

Özoğuz A, Uyan Ö, Birdal G, Iskender C, Kartal E, Lahut S, Ömür Ö, Agim ZS, Eken AG, Sen NE, Kavak P, Saygı C, Sapp PC, Keagle P, Parman Y, Tan E, Koç F, Deymeer F, Oflazer P, Hanağası H, Gürvit H, Bilgiç B, Durmuş H, Ertaş M, Kotan D, Akalın MA, Güllüoğlu H, Zarifoğlu M, Aysal F, Döşoğlu N, Bilguvar K, Günel M, Keskin Ö, Akgün T, Özçelik H, Landers JE, Brown RH, Başak AN.

Neurobiol Aging. 2015 Apr;36(4):1764.e9-18. doi: 10.1016/j.neurobiolaging.2014.12.032. Epub 2015 Jan 10.

Abstract

The frequency of amyotrophic lateral sclerosis (ALS) mutations has been extensively investigated in several populations; however, a systematic analysis in Turkish cases has not been reported so far. In this study, we screened 477 ALS patients for mutations, including 116 familial ALS patients from 82 families and 361 sporadic ALS (sALS) cases. Patients were genotyped for C9orf72 (18.3%), SOD1 (12.2%), FUS (5%), TARDBP (3.7%), and UBQLN2 (2.4%) gene mutations, which together account for approximately 40% of familial ALS in Turkey. No SOD1 mutations were detected in sALS patients; however, C9orf72 (3.1%) and UBQLN2 (0.6%) explained 3.7% of sALS in the population. Exome sequencing revealed mutations in OPTN, SPG11, DJ1, PLEKHG5, SYNE1, TRPM7, and SQSTM1 genes, many of them novel. The spectrum of mutations reflect both the distinct genetic background and the heterogeneous nature of the Turkish ALS population.

12q24 locus association with type 1 diabetes: SH2B3 or ATXN2?

Auburger G, Gispert S, Lahut S, Omür O, Damrath E, Heck M, Başak N.

World J Diabetes. 2014 Jun 15;5(3):316-27. doi: 10.4239/wjd.v5.i3.316.

Abstract

Genetic linkage analyses, genome-wide association studies of single nucleotide polymorphisms, copy number variation surveys, and mutation screenings found the human chromosomal 12q24 locus, with the genes SH2B3 and ATXN2 in its core, to be associated with an exceptionally wide spectrum of disease susceptibilities. Hematopoietic traits of red and white blood cells (like erythrocytosis and myeloproliferative disease), autoimmune disorders (like type 1 diabetes, coeliac disease, juvenile idiopathic arthritis, rheumatoid arthritis, thrombotic antiphospholipid syndrome, lupus erythematosus, multiple sclerosis, hypothyroidism and vitiligo), also vascular pathology (like kidney glomerular filtration rate deficits, serum urate levels, plasma beta-2-microglobulin levels, retinal microcirculation problems, diastolic and systolic blood pressure and hypertension, cardiovascular infarction), furthermore obesity, neurodegenerative conditions (like the polyglutamine-expansion disorder spinocerebellar ataxia type 2, Parkinson's disease, the motor-neuron disease amyotrophic lateral sclerosis, and progressive supranuclear palsy), and finally longevity were reported. Now it is important to clarify, in which ways the loss or gain of function of the locally encoded proteins SH2B3/LNK and ataxin-2, respectively, contribute to these polygenic health problems. SH2B3/LNK is known to repress the JAK2/ABL1 dependent proliferation of white blood cells. Its null mutations in human and mouse are triggers of autoimmune traits and leukemia (acute lymphoblastic leukemia or chronic myeloid leukemia-like), while missense mutations were found in erythrocytosis-1 patients. Ataxin-2 is known to act on RNA-processing and trophic receptor internalization. While its polyglutamine-expansion mediated gain-of-function causes neuronal atrophy in human and mouse, its deletion leads to obesity and insulin resistance in mice. Thus, it is conceivable that the polygenic pathogenesis of type 1 diabetes is enhanced by an SH2B3-dysregulation-mediated predisposition to autoimmune diseases that conspires with an ATXN2-deficiency-mediated predisposition to lipid and glucose metabolism pathology.

The PD-associated alpha-synuclein promoter Rep1 allele 2 shows diminished frequency in restless legs syndrome.

Lahut S, Vadasz D, Depboylu C, Ries V, Krenzer M, Stiasny-Kolster K, Basak AN, Oertel WH, Auburger G.

Neurogenetics. 2014 Aug;15(3):189-92. doi: 10.1007/s10048-014-0407-z. Epub 2014 May 27.

Abstract

Gain-of-function mutations of alpha-synuclein (SNCA) are known to trigger Parkinson's disease (PD) with striatal dopaminergic deficits and a reduction of spontaneous movements. The longest size variant (allele 2) of the complex microsatellite repeat Rep1 within the SNCA gene promoter is known to confer a PD risk. We now observed this Rep1 allele 2 to show significantly decreased frequency in restless legs syndrome (RLS) in a genotyping study of 258 patients versus 235 healthy controls from Germany. Given that RLS is a disease with increased spontaneous movements and with increased striatal dopamine signaling, these novel data appear plausible. The scarcity of this alpha-synuclein gain-of-function variant in RLS might suggest that a low alpha-synuclein function via the SNARE complex in presynaptic vesicle release and neurotransmission of the striatum contributes to RLS pathogenesis.

ATXN2 and its neighbouring gene SH2B3 are associated with increased ALS risk in the Turkish population.

Lahut S, Ömür Ö, Uyan Ö, Ağım ZS, Özoğuz A, Parman Y, Deymeer F, Oflazer P, Koç F, Özçelik H, Auburger G, Başak AN.

PLoS One. 2012;7(8):e42956. doi: 10.1371/journal.pone.0042956. Epub 2012 Aug 20.

Abstract

Expansions of the polyglutamine (polyQ) domain (≥ 34) in Ataxin-2 (ATXN2) are the primary cause of spinocerebellar ataxia type 2 (SCA2). Recent studies reported that intermediate-length (27-33) expansions increase the risk of Amyotrophic Lateral Sclerosis (ALS) in 1-4% of cases in diverse populations. This study investigates the Turkish population with respect to ALS risk, genotyping 158 sporadic, 78 familial patients and 420 neurologically healthy controls. We re-assessed the effect of ATXN2 expansions and extended the analysis for the first time to cover the ATXN2 locus with 18 Single Nucleotide Polymorphisms (SNPs) and their haplotypes. In accordance with other studies, our results confirmed that 31-32 polyQ repeats in the ATXN2 gene are associated with risk of developing ALS in 1.7% of the Turkish ALS cohort ($p=0.0172$). Additionally, a significant association of a 136 kb haplotype block across the ATXN2 and SH2B3 genes was found in 19.4% of a subset of our ALS cohort and in 10.1% of the controls ($p=0.0057$, OR: 2.23). ATXN2 and SH2B3 encode proteins that both interact with growth receptor tyrosine kinases. Our novel observations suggest that genotyping of SNPs at this locus may be useful for the study of ALS risk in a high percentage of individuals and that ATXN2 and SH2B3 variants may interact in modulating the disease pathway.

TDP-43 Proteinopatileri: Nörodejeneratif Konformasyon Bozukluğu Hastalıklarında Yeni Bir Oyuncu

TDP-43 Proteinopathies: A New Player in Neurodegenerative Diseases with Defective Protein Folding

Suna Lahut, Burçak Özeş, Soykan Ağar, A. Nazlı Başak

Türk Nöroloji Dergisi 2012; 18:1-10. doi: 10.4274/Tnd.58561

ÖZET

Hücredeki proteinlerin toplamına proteom, proteomun hücre içindeki stabil durumuna proteostaz denilir. Proteostazın korunması için, proteinlerin doğru konsantrasyonu, hatasız ekspresyonu, düzgün üç-boyutlu katlanması, translokasyonu ve gerekli durumlarda yıkımı sağlanmalıdır. Genetik ve çevresel faktörler sonucu proteinlerin yanlış katlanma ve agregasyona-yatkın bir konformasyona dönüşmesi, hücre stresini artırır. Birçok kanıt, hasarlı protein birikiminin, sadece hücre-içi süreçlerin verimliliği ve hassasiyetine doğrudan olumsuz etki yapmakla kalmadığını, düzeltilmedikleri takdirde, işlev bozukluğu şelalesini tetikleyerek, proteinopatiler olarak adlandırılan bir dizi protein konformasyonu bozukluğu hastalığına neden olduğunu göstermektedir. Günümüzde özellikle yaşlı popülasyon oranları yüksek, gelişmiş toplumları tehdit eden, Alzheimer Hastalığı (AD), Parkinson Hastalığı (PD), Huntington Hastalığı (HD), Amiyotrofik Lateral Skleroz (ALS), kanser, diyabet vb. hastalıklar genelde protein katlanma bozukluğundan kaynaklanırlar. Bu yazıda, gerek güncelliği, gerekse birçok farklı hastalıkta etkin olması nedeniyle TDP-43 proteini, neden olduğu proteinopatilerin en iyi araştırılmış örnekleri olan ALS ve FTLD üzerinden incelenmiştir.

REFERENCES

- Abeliovich, A., Y. Schmitz, I. Farinas, D. Choi-Lundberg, W.H. Ho, P.E. Castillo, N. Shinsky, J.M. Verdugo, M. Armanini, A. Ryan, M. Hynes, H. Phillips, D. Sulzer and A. Rosenthal, 2000, "Mice Lacking Alpha-Synuclein Display Functional Deficits in the Nigrostriatal Dopamine System", *Neuron*, Vol. 25, No. 1, pp. 239-252.
- Ahn, K.J., S.R. Paik, K.C. Chung and J. Kim, 2006, "Amino Acid Sequence Motifs and Mechanistic Features of the Membrane Translocation of Alpha-Synuclein", *Journal of Neurochemistry*, Vol. 97, No. 1, pp. 265-279.
- Albers, J.J., S. Vuletic and M.C. Cheung, 2012, "Role of Plasma Phospholipid Transfer Protein in Lipid and Lipoprotein Metabolism", *Biochimica et Biophysica Acta*, Vol. 1821, No. 3, pp. 345-357.
- Allen, R.P., D. Picchiatti, W.A. Hening, C. Trenkwalder, A.S. Walters and J. Montplaisi, 2003, "Restless Legs Syndrome: Diagnostic Criteria, Special Considerations, and Epidemiology. A Report from the Restless Legs Syndrome Diagnosis and Epidemiology Workshop at the National Institutes of Health", *Sleep Medicine*, Vol. 4, No. 2, pp. 101-119.
- Angot, E., J.A. Steiner, C.M. Lema Tome, P. Ekstrom, B. Mattsson, A. Bjorklund and P. Brundin, 2012, "Alpha-Synuclein Cell-to-Cell Transfer and Seeding in Grafted Dopaminergic Neurons in Vivo", *PloS one*, Vol. 7, No. 6, pp. e39465.
- Appel-Cresswell, S., C. Vilarino-Guell, M. Encarnacion, H. Sherman, I. Yu, B. Shah, D. Weir, C. Thompson, C. Szu-Tu, J. Trinh, J.O. Aasly, A. Rajput, A.H. Rajput, A. Jon Stoessl and M.J. Farrer, 2013, "Alpha-Synuclein P.H50q, a Novel Pathogenic Mutation for Parkinson's Disease", *Movement disorders : Official Journal of the Movement Disorder Society*, Vol. 28, No. 6, pp. 811-813.

- Barbour, R., K. Kling, J.P. Anderson, K. Banducci, T. Cole, L. Diep, M. Fox, J.M. Goldstein, F. Soriano, P. Seubert and T.J. Chilcote, 2008, "Red Blood Cells Are the Major Source of Alpha-Synuclein in Blood", *Neurodegenerative Diseases*, Vol. 5, No. 2, pp. 55-59.
- Bellucci, A., M. Zaltieri, L. Navarra, J. Grigoletto, C. Missale and P. Spano, 2012, "From Alpha-Synuclein to Synaptic Dysfunctions: New Insights into the Pathophysiology of Parkinson's Disease", *Brain Research*, Vol. 1476, pp. 183-202.
- Bendor, J.T., T.P. Logan and R.H. Edwards, 2013, "The Function of Alpha-Synuclein", *Neuron*, Vol. 79, No. 6, pp. 1044-1066.
- Berg, D., K. Marek, G.W. Ross and W. Poewe, 2012, "Defining at-Risk Populations for Parkinson's Disease: Lessons from Ongoing Studies", *Movement Disorders : Official Journal of the Movement Disorder Society*, Vol. 27, No. 5, pp. 656-665.
- Bonifati, V., 2007, "Lrrk2 Low-Penetrance Mutations (Gly2019ser) and Risk Alleles (Gly2385arg)-Linking Familial and Sporadic Parkinson's Disease", *Neurochemistry Research*, Vol. 32, No. 10, pp. 1700-1708.
- Braak, H., R.A. de Vos, J. Bohl and K. Del Tredici, 2006, "Gastric Alpha-Synuclein Immunoreactive Inclusions in Meissner's and Auerbach's Plexuses in Cases Staged for Parkinson's Disease-Related Brain Pathology", *Neuroscience Letters*, Vol. 396, No. 1, pp. 67-72.
- Braak, H., K. Del Tredici, U. Rub, R.A. de Vos, E.N. Jansen Steur and E. Braak, 2003, "Staging of Brain Pathology Related to Sporadic Parkinson's Disease", *Neurobiology of Aging*, Vol. 24, No. 2, pp. 197-211.
- Brundin, P., J.Y. Li, J.L. Holton, O. Lindvall and T. Revesz, 2008, "Research in Motion: The Enigma of Parkinson's Disease Pathology Spread", *Nature Reviews. Neuroscience*, Vol. 9, No. 10, pp. 741-745.

- Cabin, D.E., K. Shimazu, D. Murphy, N.B. Cole, W. Gottschalk, K.L. McIlwain, B. Orrison, A. Chen, C.E. Ellis, R. Paylor, B. Lu and R.L. Nussbaum, 2002, "Synaptic Vesicle Depletion Correlates with Attenuated Synaptic Responses to Prolonged Repetitive Stimulation in Mice Lacking Alpha-Synuclein", *The Journal of Neuroscience : The Official Journal of the Society for Neuroscience*, Vol. 22, No. 20, pp. 8797-8807.
- Chen, X., D.R. Tomchick, E. Kovrigin, D. Arac, M. Machius, T.C. Sudhof and J. Rizo, 2002, "Three-Dimensional Structure of the Complexin/Snare Complex", *Neuron*, Vol. 33, No. 3, pp. 397-409.
- Chiba-Falek, O. and R.L. Nussbaum, 2001, "Effect of Allelic Variation at the Nacp-Rep1 Repeat Upstream of the Alpha-Synuclein Gene (Snca) on Transcription in a Cell Culture Luciferase Reporter System", *Human Molecular Genetics*, Vol. 10, No. 26, pp. 3101-3109.
- Chung, C.Y., J.B. Koprach, P.J. Hallett and O. Isacson, 2009a, "Functional Enhancement and Protection of Dopaminergic Terminals by Rab3b Overexpression", *Proceedings of the National Academy of Sciences of the United States of America*, Vol. 106, No. 52, pp. 22474-22479.
- Chung, C.Y., J.B. Koprach, H. Siddiqi and O. Isacson, 2009b, "Dynamic Changes in Presynaptic and Axonal Transport Proteins Combined with Striatal Neuroinflammation Precede Dopaminergic Neuronal Loss in a Rat Model of Aav Alpha-Synucleinopathy", *The Journal of Neuroscience : The Official Journal of the Society for Neuroscience*, Vol. 29, No. 11, pp. 3365-3373.
- Corti, O., S. Lesage and A. Brice, 2011, "What Genetics Tells Us About the Causes and Mechanisms of Parkinson's Disease", *Physiological Reviews*, Vol. 91, No. 4, pp. 1161-1218.
- Crabtree, D., M. Dodson, X. Ouyang, M. Boyer-Guittaut, Q. Liang, M.E. Ballestas, N. Fineberg and J. Zhang, 2014, "Over-Expression of an Inactive Mutant Cathepsin D

Increases Endogenous Alpha-Synuclein and Cathepsin B Activity in Sh-Sy5y Cells", *Journal of Neurochemistry*, Vol. 128, No. 6, pp. 950-961.

Danzer, K.M., L.R. Kranich, W.P. Ruf, O. Cagsal-Getkin, A.R. Winslow, L. Zhu, C.R. Vanderburg and P.J. McLean, 2012, "Exosomal Cell-to-Cell Transmission of Alpha Synuclein Oligomers", *Molecular Neurodegeneration*, Vol. 7, pp. 42.

Danzer, K.M., S.K. Krebs, M. Wolff, G. Birk and B. Hengerer, 2009, "Seeding Induced by Alpha-Synuclein Oligomers Provides Evidence for Spreading of Alpha-Synuclein Pathology", *Journal of Neurochemistry*, Vol. 111, No. 1, pp. 192-203.

Danzer, K.M., W.P. Ruf, P. Putcha, D. Joyner, T. Hashimoto, C. Glabe, B.T. Hyman and P.J. McLean, 2011, "Heat-Shock Protein 70 Modulates Toxic Extracellular Alpha-Synuclein Oligomers and Rescues Trans-Synaptic Toxicity", *FASEB Journal*, Vol. 25, No. 1, pp. 326-336.

Dauer, W., N. Kholodilov, M. Vila, A.C. Trillat, R. Goodchild, K.E. Larsen, R. Staal, K. Tieu, Y. Schmitz, C.A. Yuan, M. Rocha, V. Jackson-Lewis, S. Hersch, D. Sulzer, S. Przedborski, R. Burke and R. Hen, 2002, "Resistance of Alpha -Synuclein Null Mice to the Parkinsonian Neurotoxin Mptp", *Proceedings of the National Academy of Sciences of the United States of America*, Vol. 99, No. 22, pp. 14524-14529.

Davies, S.E., P.J. Hallett, T. Moens, G. Smith, E. Mangano, H.T. Kim, A.L. Goldberg, J.L. Liu, O. Isacson and G.K. Tofaris, 2014, "Enhanced Ubiquitin-Dependent Degradation by Nedd4 Protects against Alpha-Synuclein Accumulation and Toxicity in Animal Models of Parkinson's Disease", *Neurobiology of Disease*, Vol. 64, pp. 79-87.

Desplats, P., H.J. Lee, E.J. Bae, C. Patrick, E. Rockenstein, L. Crews, B. Spencer, E. Masliah and S.J. Lee, 2009, "Inclusion Formation and Neuronal Cell Death through Neuron-to-Neuron Transmission of Alpha-Synuclein", *Proceedings of the National Academy of Sciences of the United States of America*, Vol. 106, No. 31, pp. 13010-13015.

- Di Fonzo, A., C. Tassorelli, M. De Mari, H.F. Chien, J. Ferreira, C.F. Rohe, G. Riboldazzi, A. Antonini, G. Albani, A. Mauro, R. Marconi, G. Abbruzzese, L. Lopiano, E. Fincati, M. Guidi, P. Marini, F. Stocchi, M. Onofri, V. Toni, M. Tinazzi, G. Fabbrini, P. Lamberti, N. Vanacore, G. Meco, P. Leitner, R.J. Uitti, Z.K. Wszolek, T. Gasser, E.J. Simons, G.J. Breedveld, S. Goldwurm, G. Pezzoli, C. Sampaio, E. Barbosa, E. Martignoni, B.A. Oostra, V. Bonifati and N. Italian Parkinson's Genetics, 2006, "Comprehensive Analysis of the Lrrk2 Gene in Sixty Families with Parkinson's Disease", *European Journal of Human Genetics : EJHG*, Vol. 14, No. 3, pp. 322-331.
- Djarmati, A., K. Hedrich, M. Svetel, N. Schafer, V. Juric, S. Vukosavic, R. Hering, O. Riess, S. Romac, C. Klein and V. Kostic, 2004, "Detection of Parkin (Park2) and Djl (Park7) Mutations in Early-Onset Parkinson Disease: Parkin Mutation Frequency Depends on Ethnic Origin of Patients", *Human Mutations*, Vol. 23, No. 5, pp. 525.
- Dong, W., J.J. Albers and S. Vuletic, 2009, "Phospholipid Transfer Protein Reduces Phosphorylation of Tau in Human Neuronal Cells", *Journal of Neuroscience Research*, Vol. 87, No. 14, pp. 3176-3185.
- Doyle, K.M., D. Kennedy, A.M. Gorman, S. Gupta, S.J. Healy and A. Samali, 2011, "Unfolded Proteins and Endoplasmic Reticulum Stress in Neurodegenerative Disorders", *Journal of Cellular and Molecular Medicine*, Vol. 15, No. 10, pp. 2025-2039.
- Fahn, S., 2003, "Description of Parkinson's Disease as a Clinical Syndrome", *Annals of the New York Academy of Sciences*, Vol. 991, pp. 1-14.
- Feng, L.R., H.J. Federoff, S. Vicini and K.A. Maguire-Zeiss, 2010, "Alpha-Synuclein Mediates Alterations in Membrane Conductance: A Potential Role for Alpha-Synuclein Oligomers in Cell Vulnerability", *The European Journal of Neuroscience*, Vol. 32, No. 1, pp. 10-17.

- Fisher, L.W., D.A. Torchia, B. Fohr, M.F. Young and N.S. Fedarko, 2001, "Flexible Structures of Sibling Proteins, Bone Sialoprotein, and Osteopontin", *Biochemical and Biophysical Research Communications*, Vol. 280, No. 2, pp. 460-465.
- Fortin, D.L., V.M. Nemani, S.M. Voglmaier, M.D. Anthony, T.A. Ryan and R.H. Edwards, 2005, "Neural Activity Controls the Synaptic Accumulation of Alpha-Synuclein", *The Journal of Neuroscience : The Official Journal of the Society for Neuroscience*, Vol. 25, No. 47, pp. 10913-10921.
- Fuchs, J., C. Nilsson, J. Kachergus, M. Munz, E.M. Larsson, B. Schule, J.W. Langston, F.A. Middleton, O.A. Ross, M. Hulihan, T. Gasser and M.J. Farrer, 2007, "Phenotypic Variation in a Large Swedish Pedigree Due to Snca Duplication and Triplication", *Neurology*, Vol. 68, No. 12, pp. 916-922.
- Furukawa, K., M. Matsuzaki-Kobayashi, T. Hasegawa, A. Kikuchi, N. Sugeno, Y. Itoyama, Y. Wang, P.J. Yao, I. Bushlin and A. Takeda, 2006, "Plasma Membrane Ion Permeability Induced by Mutant Alpha-Synuclein Contributes to the Degeneration of Neural Cells", *Journal of Neurochemistry*, Vol. 97, No. 4, pp. 1071-1077.
- Gallegos, S., C. Pacheco, C. Peters, C.M. Opazo and L.G. Aguayo, 2015, "Features of Alpha-Synuclein That Could Explain the Progression and Irreversibility of Parkinson's Disease", *Frontiers in Neuroscience*, Vol. 9, pp. 59.
- Gao, C., H. Guo, J. Wei and P.C. Kuo, 2003, "Osteopontin Inhibits Expression of Cytochrome C Oxidase in Raw 264.7 Murine Macrophages", *Biochemical and Biophysical Research Communications*, Vol. 309, No. 1, pp. 120-125.
- Gardai, S.J., W. Mao, B. Schule, M. Babcock, S. Schoebel, C. Lorenzana, J. Alexander, S. Kim, H. Glick, K. Hilton, J.K. Fitzgerald, M. Buttini, S.S. Chiou, L. McConlogue, J.P. Anderson, D.B. Schenk, F. Bard, J.W. Langston, T. Yednock and J.A. Johnston, 2013, "Elevated Alpha-Synuclein Impairs Innate Immune Cell Function

- and Provides a Potential Peripheral Biomarker for Parkinson's Disease", *PloS One*, Vol. 8, No. 8, pp. e71634.
- Gasser, T., 2009, "Genomic and Proteomic Biomarkers for Parkinson Disease", *Neurology*, Vol. 72, No. 7 Suppl, pp. S27-31.
- Gasser, T., J. Hardy and Y. Mizuno, 2011, "Milestones in Pd Genetics", *Movement Disorders : Official Journal of the Movement Disorder Society*, Vol. 26, No. 6, pp. 1042-1048.
- Gautier, T. and L. Lagrost, 2011, "Plasma Pltp (Phospholipid-Transfer Protein): An Emerging Role in 'Reverse Lipopolysaccharide Transport' and Innate Immunity", *Biochemical Society Transactions*, Vol. 39, No. 4, pp. 984-988.
- George, J.M., 2002, "The Synucleins", *Genome Biology*, Vol. 3, No. 1, pp. REVIEWS3002.
- Ghosh, D., M. Mondal, G.M. Mohite, P.K. Singh, P. Ranjan, A. Anoop, S. Ghosh, N.N. Jha, A. Kumar and S.K. Maji, 2013, "The Parkinson's Disease-Associated H50q Mutation Accelerates Alpha-Synuclein Aggregation in Vitro", *Biochemistry*, Vol. 52, No. 40, pp. 6925-6927.
- Giachelli, C.M. and S. Steitz, 2000, "Osteopontin: A Versatile Regulator of Inflammation and Biomineralization", *Matrix Biology : Journal of the International Society for Matrix Biology*, Vol. 19, No. 7, pp. 615-622.
- Gispert, S., A. Kurz, N. Brehm, K. Rau, M. Walter, O. Riess and G. Auburger, 2014, "Complexin-1 and Foxp1 Expression Changes Are Novel Brain Effects of Alpha-Synuclein Pathology", *Molecular Neurobiology*.
- Graeber, M.B. and W.J. Streit, 2010, "Microglia: Biology and Pathology", *Acta Neuropathologica*, Vol. 119, No. 1, pp. 89-105.

- Hammond, C., R. Ammari, B. Bioulac and L. Garcia, 2008, "Latest View on the Mechanism of Action of Deep Brain Stimulation", *Movement Disorders : Official Journal of the Movement Disorder Society*, Vol. 23, No. 15, pp. 2111-2121.
- Hansen, C. and J.Y. Li, 2012, "Beyond Alpha-Synuclein Transfer: Pathology Propagation in Parkinson's Disease", *Trends in Molecular Medicine*, Vol. 18, No. 5, pp. 248-255.
- Hattori, N., H. Shimura, S. Kubo, T. Kitada, M. Wang, S. Asakawa, S. Minashima, N. Shimizu, T. Suzuki, K. Tanaka and Y. Mizuno, 2000, "Autosomal Recessive Juvenile Parkinsonism: A Key to Understanding Nigral Degeneration in Sporadic Parkinson's Disease", *Neuropathology*, Vol. 20 Suppl, pp. S85-90.
- Healy, D.G., M. Falchi, S.S. O'Sullivan, V. Bonifati, A. Durr, S. Bressman, A. Brice, J. Aasly, C.P. Zabetian, S. Goldwurm, J.J. Ferreira, E. Tolosa, D.M. Kay, C. Klein, D.R. Williams, C. Marras, A.E. Lang, Z.K. Wszolek, J. Berciano, A.H. Schapira, T. Lynch, K.P. Bhatia, T. Gasser, A.J. Lees, N.W. Wood and L.C. International, 2008, "Phenotype, Genotype, and Worldwide Genetic Penetrance of Lrrk2-Associated Parkinson's Disease: A Case-Control Study", *Lancet Neurology*, Vol. 7, No. 7, pp. 583-590.
- Hettiarachchi, N.T., A. Parker, M.L. Dallas, K. Pennington, C.C. Hung, H.A. Pearson, J.P. Boyle, P. Robinson and C. Peers, 2009, "Alpha-Synuclein Modulation of Ca²⁺ Signaling in Human Neuroblastoma (Sh-Sy5y) Cells", *Journal of Neurochemistry*, Vol. 111, No. 5, pp. 1192-1201.
- Hirsch, E.C. and S. Hunot, 2009, "Neuroinflammation in Parkinson's Disease: A Target for Neuroprotection?", *The Lancet Neurology*, Vol. 8, No. 4, pp. 382-397.
- Hoffman-Zacharska, D., D. Kozirowski, O.A. Ross, M. Milewski, J. Poznanski, M. Jurek, Z.K. Wszolek, A. Soto-Ortolaza, J. Slawek, P. Janik, Z. Jamrozik, A. Potulska-Chromik, B. Jasinska-Myga, G. Opala, A. Krygowska-Wajs, K. Czyzewski, D.W. Dickson, J. Bal and A. Friedman, 2013, "Novel A18t and Pa29s Substitutions in

Alpha-Synuclein May Be Associated with Sporadic Parkinson's Disease", *Parkinsonism & Related Disorders*, Vol. 19, No. 11, pp. 1057-1060.

Ibanez, P., S. Lesage, S. Janin, E. Lohmann, F. Durif, A. Destee, A.M. Bonnet, C. Brefel-Courbon, S. Heath, D. Zelenika, Y. Agid, A. Durr, A. Brice and G. French Parkinson's Disease Genetics Study, 2009, "Alpha-Synuclein Gene Rearrangements in Dominantly Inherited Parkinsonism: Frequency, Phenotype, and Mechanisms", *Archives of Neurology*, Vol. 66, No. 1, pp. 102-108.

Iczkiewicz, J., M.J. Jackson, L.A. Smith, S. Rose and P. Jenner, 2006, "Osteopontin Expression in Substantia Nigra in Mptp-Treated Primates and in Parkinson's Disease", *Brain Research*, Vol. 1118, No. 1, pp. 239-250.

Jain, N., K. Bhasne, M. Hemaswathi and S. Mukhopadhyay, 2013, "Structural and Dynamical Insights into the Membrane-Bound Alpha-Synuclein", *PloS One*, Vol. 8, No. 12, pp. e83752.

Kageyama, T., M. Nakamura, A. Matsuo, Y. Yamasaki, Y. Takakura, M. Hashida, Y. Kanai, M. Naito, T. Tsuruo, N. Minato and S. Shimohama, 2000, "The 4f2hc/Lat1 Complex Transports L-Dopa across the Blood-Brain Barrier", *Brain Research*, Vol. 879, No. 1-2, pp. 115-121.

Kahle, P.J., 2008, "Alpha-Synucleinopathy Models and Human Neuropathology: Similarities and Differences", *Acta Neuropathologica*, Vol. 115, No. 1, pp. 87-95.

Khalaf, O., B. Fauvet, A. Oueslati, I. Dikiy, A.L. Mahul-Mellier, F.S. Ruggeri, M.K. Mbefo, F. Vercautse, G. Dietler, S.J. Lee, D. Eliezer and H.A. Lashuel, 2014, "The H50q Mutation Enhances Alpha-Synuclein Aggregation, Secretion, and Toxicity", *The Journal of Biological Chemistry*, Vol. 289, No. 32, pp. 21856-21876.

- Kieburz, K. and K.B. Wunderle, 2013, "Parkinson's Disease: Evidence for Environmental Risk Factors", *Movement Disorders : Official Journal of the Movement Disorder Society*, Vol. 28, No. 1, pp. 8-13.
- Kim, C., D.H. Ho, J.E. Suk, S. You, S. Michael, J. Kang, S. Joong Lee, E. Masliah, D. Hwang, H.J. Lee and S.J. Lee, 2013, "Neuron-Released Oligomeric Alpha-Synuclein Is an Endogenous Agonist of Tlr2 for Paracrine Activation of Microglia", *Nature Communications*, Vol. 4, pp. 1562.
- Kingsbury, A.E., R. Bandopadhyay, L. Silveira-Moriyama, H. Ayling, C. Kallis, W. Sterlacci, H. Maeir, W. Poewe and A.J. Lees, 2010, "Brain Stem Pathology in Parkinson's Disease: An Evaluation of the Braak Staging Model", *Movement Disorders : Official Journal of the Movement Disorder Society*, Vol. 25, No. 15, pp. 2508-2515.
- Kumazawa, R., H. Tomiyama, Y. Li, Y. Imamichi, M. Funayama, H. Yoshino, F. Yokochi, T. Fukusako, Y. Takehisa, K. Kashihara, T. Kondo, B. Elibol, S. Bostantjopoulou, T. Toda, H. Takahashi, F. Yoshii, Y. Mizuno and N. Hattori, 2008, "Mutation Analysis of the Pink1 Gene in 391 Patients with Parkinson Disease", *Archives of Neurology*, Vol. 65, No. 6, pp. 802-808.
- Kurz, A., K.L. Double, I. Lastres-Becker, A. Tozzi, M. Tantucci, V. Bockhart, M. Bonin, M. Garcia-Arencibia, S. Nuber, F. Schlaudraff, B. Liss, J. Fernandez-Ruiz, M. Gerlach, U. Wullner, H. Luddens, P. Calabresi, G. Auburger and S. Gispert, 2010, "A53t-Alpha-Synuclein Overexpression Impairs Dopamine Signaling and Striatal Synaptic Plasticity in Old Mice", *PloS One*, Vol. 5, No. 7, pp. e11464.
- Lahut, S., D. Vadasz, C. Depboylu, V. Ries, M. Krenzer, K. Stiasny-Kolster, A.N. Basak, W.H. Oertel and G. Auburger, 2014, "The Pd-Associated Alpha-Synuclein Promoter Rep1 Allele 2 Shows Diminished Frequency in Restless Legs Syndrome", *Neurogenetics*, Vol. 15, No. 3, pp. 189-192.

- Lashuel, H.A., C.R. Overk, A. Oueslati and E. Masliah, 2013, "The Many Faces of Alpha-Synuclein: From Structure and Toxicity to Therapeutic Target", *Nature Reviews. Neuroscience*, Vol. 14, No. 1, pp. 38-48.
- Li, J.Y., E. Englund, J.L. Holton, D. Soulet, P. Hagell, A.J. Lees, T. Lashley, N.P. Quinn, S. Rehncrona, A. Bjorklund, H. Widner, T. Revesz, O. Lindvall and P. Brundin, 2008, "Lewy Bodies in Grafted Neurons in Subjects with Parkinson's Disease Suggest Host-to-Graft Disease Propagation", *Nature Medicine*, Vol. 14, No. 5, pp. 501-503.
- Lill, C.M., J.T. Roehr, M.B. McQueen, F.K. Kavvoura, S. Bagade, B.M. Schjeide, L.M. Schjeide, E. Meissner, U. Zauft, N.C. Allen, T. Liu, M. Schilling, K.J. Anderson, G. Beecham, D. Berg, J.M. Biernacka, A. Brice, A.L. DeStefano, C.B. Do, N. Eriksson, S.A. Factor, M.J. Farrer, T. Foroud, T. Gasser, T. Hamza, J.A. Hardy, P. Heutink, E.M. Hill-Burns, C. Klein, J.C. Latourelle, D.M. Maraganore, E.R. Martin, M. Martinez, R.H. Myers, M.A. Nalls, N. Pankratz, H. Payami, W. Satake, W.K. Scott, M. Sharma, A.B. Singleton, K. Stefansson, T. Toda, J.Y. Tung, J. Vance, N.W. Wood, C.P. Zabetian, P. Young, R.E. Tanzi, M.J. Khoury, F. Zipp, H. Lehrach, J.P. Ioannidis and L. Bertram, 2012, "Comprehensive Research Synopsis and Systematic Meta-Analyses in Parkinson's Disease Genetics: The Pdgene Database", *PLoS Genetics*, Vol. 8, No. 3, pp. e1002548.
- Lim, Y., V.M. Kehm, E.B. Lee, J.H. Soper, C. Li, J.Q. Trojanowski and V.M. Lee, 2011, "Alpha-Syn Suppression Reverses Synaptic and Memory Defects in a Mouse Model of Dementia with Lewy Bodies", *The Journal of Neuroscience : The Official Journal of the Society for Neuroscience*, Vol. 31, No. 27, pp. 10076-10087.
- Lin, J.C. and A. Rosenthal, 2003, "Molecular Mechanisms Controlling the Development of Dopaminergic Neurons", *Seminars in Cell & Developmental Biology*, Vol. 14, No. 3, pp. 175-180.

- Lucin, K.M. and T. Wyss-Coray, 2009, "Immune Activation in Brain Aging and Neurodegeneration: Too Much or Too Little?", *Neuron*, Vol. 64, No. 1, pp. 110-122.
- Luk, K.C., V. Kehm, J. Carroll, B. Zhang, P. O'Brien, J.Q. Trojanowski and V.M. Lee, 2012, "Pathological Alpha-Synuclein Transmission Initiates Parkinson-Like Neurodegeneration in Nontransgenic Mice", *Science (New York, N.Y.)*, Vol. 338, No. 6109, pp. 949-953.
- Luk, K.C., C. Song, P. O'Brien, A. Stieber, J.R. Branch, K.R. Brunden, J.Q. Trojanowski and V.M. Lee, 2009, "Exogenous Alpha-Synuclein Fibrils Seed the Formation of Lewy Body-Like Intracellular Inclusions in Cultured Cells", *Proceedings of the National Academy of Sciences of the United States of America*, Vol. 106, No. 47, pp. 20051-20056.
- Maetzler, W., D. Berg, N. Schalamberidze, A. Melms, K. Schott, J.C. Mueller, L. Liaw, T. Gasser and C. Nitsch, 2007, "Osteopontin Is Elevated in Parkinson's Disease and Its Absence Leads to Reduced Neurodegeneration in the Mptp Model", *Neurobiology of Disease*, Vol. 25, No. 3, pp. 473-482.
- Manson, A., P. Stirpe and A. Schrag, 2012, "Levodopa-Induced-Dyskinesias Clinical Features, Incidence, Risk Factors, Management and Impact on Quality of Life", *Journal of Parkinson's Disease*, Vol. 2, No. 3, pp. 189-198.
- Maraganore, D.M., M. de Andrade, A. Elbaz, M.J. Farrer, J.P. Ioannidis, R. Kruger, W.A. Rocca, N.K. Schneider, T.G. Lesnick, S.J. Lincoln, M.M. Hulihan, J.O. Aasly, T. Ashizawa, M.C. Chartier-Harlin, H. Checkoway, C. Ferrarese, G. Hadjigeorgiou, N. Hattori, H. Kawakami, J.C. Lambert, T. Lynch, G.D. Mellick, S. Papapetropoulos, A. Parsian, A. Quattrone, O. Riess, E.K. Tan and C. Van Broeckhoven, 2006, "Collaborative Analysis of Alpha-Synuclein Gene Promoter Variability and Parkinson Disease", *JAMA*, Vol. 296, No. 6, pp. 661-670.

- McMahon, H.T., M. Missler, C. Li and T.C. Sudhof, 1995, "Complexins: Cytosolic Proteins That Regulate Snap Receptor Function", *Cell*, Vol. 83, No. 1, pp. 111-119.
- Mellick, G.D., D.M. Maraganore and P.A. Silburn, 2005, "Australian Data and Meta-Analysis Lend Support for Alpha-Synuclein (Nacp-Rep1) as a Risk Factor for Parkinson's Disease", *Neuroscience Letters*, Vol. 375, No. 2, pp. 112-116.
- Mizuta, I., M. Nishimura, E. Mizuta, S. Yamasaki, M. Ohta and S. Kuno, 2002, "Meta-Analysis of Alpha Synuclein/ Nacp Polymorphism in Parkinson's Disease in Japan", *Journal of Neurology, Neurosurgery, and Psychiatry*, Vol. 73, No. 3, pp. 350.
- Nakamura, K., V.M. Nemani, F. Azarbal, G. Skibinski, J.M. Levy, K. Egami, L. Munishkina, J. Zhang, B. Gardner, J. Wakabayashi, H. Sesaki, Y. Cheng, S. Finkbeiner, R.L. Nussbaum, E. Masliah and R.H. Edwards, 2011, "Direct Membrane Association Drives Mitochondrial Fission by the Parkinson Disease-Associated Protein Alpha-Synuclein", *The Journal of Biological Chemistry*, Vol. 286, No. 23, pp. 20710-20726.
- Nussbaum, R.L. and C.E. Ellis, 2003, "Alzheimer's Disease and Parkinson's Disease", *The New England Journal of Medicine*, Vol. 348, No. 14, pp. 1356-1364.
- Obeso, J.A., M. Rodriguez-Oroz, C. Marin, F. Alonso, I. Zamarbide, J.L. Lanciego and M. Rodriguez-Diaz, 2004, "The Origin of Motor Fluctuations in Parkinson's Disease: Importance of Dopaminergic Innervation and Basal Ganglia Circuits", *Neurology*, Vol. 62, No. 1 Suppl 1, pp. S17-30.
- Owen, A.M., 2004, "Cognitive Dysfunction in Parkinson's Disease: The Role of Frontostriatal Circuitry", *The Neuroscientist : A Review Journal Bringing Neurobiology, Neurology and Psychiatry*, Vol. 10, No. 6, pp. 525-537.
- Parent, M. and A. Parent, 2010, "Substantia Nigra and Parkinson's Disease: A Brief History of Their Long and Intimate Relationship", *The Canadian Journal of*

Neurological Sciences. Le Journal Canadien des Sciences Neurologiques, Vol. 37, No. 3, pp. 313-319.

Parihar, M.S., A. Parihar, M. Fujita, M. Hashimoto and P. Ghafourifar, 2008, "Mitochondrial Association of Alpha-Synuclein Causes Oxidative Stress", *Cellular and Molecular Life Sciences : CMLS*, Vol. 65, No. 7-8, pp. 1272-1284.

Park, S.M., H.Y. Jung, H.O. Kim, H. Rhim, S.R. Paik, K.C. Chung, J.H. Park and J. Kim, 2002, "Evidence That Alpha-Synuclein Functions as a Negative Regulator of Ca(++)-Dependent Alpha-Granule Release from Human Platelets", *Blood*, Vol. 100, No. 7, pp. 2506-2514.

Pasanen, P., L. Myllykangas, M. Siitonen, A. Raunio, S. Kaakkola, J. Lyytinen, P.J. Tienari, M. Poyhonen and A. Paetau, 2014, "Novel Alpha-Synuclein Mutation A53e Associated with Atypical Multiple System Atrophy and Parkinson's Disease-Type Pathology", *Neurobiology of Aging*, Vol. 35, No. 9, pp. 2180 e2181-2185.

Petrucelli, L., C. O'Farrell, P.J. Lockhart, M. Baptista, K. Kehoe, L. Vink, P. Choi, B. Wolozin, M. Farrer, J. Hardy and M.R. Cookson, 2002, "Parkin Protects against the Toxicity Associated with Mutant Alpha-Synuclein: Proteasome Dysfunction Selectively Affects Catecholaminergic Neurons", *Neuron*, Vol. 36, No. 6, pp. 1007-1019.

Plotegher, N., E. Greggio, M. Bisaglia and L. Bubacco, 2014, "Biophysical Groundwork as a Hinge to Unravel the Biology of Alpha-Synuclein Aggregation and Toxicity", *Quarterly Reviews of Biophysics*, Vol. 47, No. 1, pp. 1-48.

Polymeropoulos, M.H., C. Lavedan, E. Leroy, S.E. Ide, A. Dehejia, A. Dutra, B. Pike, H. Root, J. Rubenstein, R. Boyer, E.S. Stenroos, S. Chandrasekharappa, A. Athanassiadou, T. Papapetropoulos, W.G. Johnson, A.M. Lazzarini, R.C. Duvoisin, G. Di Iorio, L.I. Golbe and R.L. Nussbaum, 1997, "Mutation in the Alpha-Synuclein Gene Identified in Families with Parkinson's Disease", *Science (New York, N.Y.)*, Vol. 276, No. 5321, pp. 2045-2047.

- Proukakis, C., C.G. Dudzik, T. Brier, D.S. MacKay, J.M. Cooper, G.L. Millhauser, H. Houlden and A.H. Schapira, 2013, "A Novel Alpha-Synuclein Missense Mutation in Parkinson Disease", *Neurology*, Vol. 80, No. 11, pp. 1062-1064.
- Reim, K., M. Mansour, F. Varoqueaux, H.T. McMahon, T.C. Sudhof, N. Brose and C. Rosenmund, 2001, "Complexins Regulate a Late Step in Ca²⁺-Dependent Neurotransmitter Release", *Cell*, Vol. 104, No. 1, pp. 71-81.
- Reyes, J.F., N.L. Rey, L. Bousset, R. Melki, P. Brundin and E. Angot, 2014, "Alpha-Synuclein Transfers from Neurons to Oligodendrocytes", *Glia*, Vol. 62, No. 3, pp. 387-398.
- Roggero, C.M., G.A. De Blas, H. Dai, C.N. Tomes, J. Rizo and L.S. Mayorga, 2007, "Complexin/Synaptotagmin Interplay Controls Acrosomal Exocytosis", *The Journal of Biological Chemistry*, Vol. 282, No. 36, pp. 26335-26343.
- Ross, O.A., A.T. Braithwaite, L.M. Skipper, J. Kachergus, M.M. Hulihan, F.A. Middleton, K. Nishioka, J. Fuchs, T. Gasser, D.M. Maraganore, C.H. Adler, L. Larvor, M.C. Chartier-Harlin, C. Nilsson, J.W. Langston, K. Gwinn, N. Hattori and M.J. Farrer, 2008, "Genomic Investigation of Alpha-Synuclein Multiplication and Parkinsonism", *Annual Neurology*, Vol. 63, No. 6, pp. 743-750.
- Samaranch, L., O. Lorenzo-Betancor, J.M. Arbelo, I. Ferrer, E. Lorenzo, J. Irigoyen, M.A. Pastor, C. Marrero, C. Isla, J. Herrera-Henriquez and P. Pastor, 2010, "Pink1-Linked Parkinsonism Is Associated with Lewy Body Pathology", *Brain*, Vol. 133, No. Pt 4, pp. 1128-1142.
- Santiago, J.A. and J.A. Potashkin, 2015, "Network-Based Metaanalysis Identifies Hnf4a and Ptbpl as Longitudinally Dynamic Biomarkers for Parkinson's Disease", *Proceedings of the National Academy of Sciences of the United States of America*, Vol. 112, No. 7, pp. 2257-2262.

- Sato, H., S. Arawaka, S. Hara, S. Fukushima, K. Koga, S. Koyama and T. Kato, 2011, "Authentically Phosphorylated Alpha-Synuclein at Ser129 Accelerates Neurodegeneration in a Rat Model of Familial Parkinson's Disease", *The Journal of Neuroscience : The Official Journal of the Society for Neuroscience*, Vol. 31, No. 46, pp. 16884-16894.
- Schapira, A.H., 2006, "Etiology of Parkinson's Disease", *Neurology*, Vol. 66, No. 10 Suppl 4, pp. S10-23.
- Scherzer, C.R., A.C. Eklund, L.J. Morse, Z. Liao, J.J. Locascio, D. Fefer, M.A. Schwarzschild, M.G. Schlossmacher, M.A. Hauser, J.M. Vance, L.R. Sudarsky, D.G. Standaert, J.H. Growdon, R.V. Jensen and S.R. Gullans, 2007, "Molecular Markers of Early Parkinson's Disease Based on Gene Expression in Blood", *Proceedings of the National Academy of Sciences of the United States of America*, Vol. 104, No. 3, pp. 955-960.
- Schrempf, W., M.D. Brandt, A. Storch and H. Reichmann, 2014, "Sleep Disorders in Parkinson's Disease", *Journal of Parkinson's Disease*, Vol. 4, No. 2, pp. 211-221.
- Seiler, F., J. Malsam, J.M. Krause and T.H. Sollner, 2009, "A Role of Complexin-Lipid Interactions in Membrane Fusion", *FEBS Letters*, Vol. 583, No. 14, pp. 2343-2348.
- Shi, M., J. Movius, R. Dator, P. Aro, Y. Zhao, C. Pan, X. Lin, T.K. Bammler, T. Stewart, C.P. Zabetian, E.R. Peskind, S.C. Hu, J.F. Quinn, D.R. Galasko and J. Zhang, 2015, "Cerebrospinal Fluid Peptides as Potential Parkinson Disease Biomarkers: A Staged Pipeline for Discovery and Validation", *Molecular & Cellular Proteomics : MCP*, Vol. 14, No. 3, pp. 544-555.
- Shin, E.C., S.E. Cho, D.K. Lee, M.W. Hur, S.R. Paik, J.H. Park and J. Kim, 2000, "Expression Patterns of Alpha-Synuclein in Human Hematopoietic Cells and in Drosophila at Different Developmental Stages", *Molecules and Cells*, Vol. 10, No. 1, pp. 65-70.

- Sian-Hulsmann, J., C. Monoranu, S. Strobel and P. Riederer, 2015, "Lewy Bodies: A Spectator or Salient Killer?", *CNS & Neurological Disorders Drug Targets*.
- Singleton, A.B., M.J. Farrer and V. Bonifati, 2013, "The Genetics of Parkinson's Disease: Progress and Therapeutic Implications", *Movement Disorders : Official Journal of the Movement Disorder Society*, Vol. 28, No. 1, pp. 14-23.
- Smith, W.W., H. Jiang, Z. Pei, Y. Tanaka, H. Morita, A. Sawa, V.L. Dawson, T.M. Dawson and C.A. Ross, 2005, "Endoplasmic Reticulum Stress and Mitochondrial Cell Death Pathways Mediate A53t Mutant Alpha-Synuclein-Induced Toxicity", *Human Molecular Genetics*, Vol. 14, No. 24, pp. 3801-3811.
- Snyder, H., K. Mensah, C. Theisler, J. Lee, A. Matouschek and B. Wolozin, 2003, "Aggregated and Monomeric Alpha-Synuclein Bind to the S6' Proteasomal Protein and Inhibit Proteasomal Function", *The Journal of Biological Chemistry*, Vol. 278, No. 14, pp. 11753-11759.
- Sodek, J., B. Ganss and M.D. McKee, 2000, "Osteopontin", *Critical Reviews in Oral Biology and Medicine : An Official Publication of the American Association of Oral Biologists*, Vol. 11, No. 3, pp. 279-303.
- Spadafora, P., G. Annesi, A.A. Pasqua, P. Serra, I.C. Ciro Candiano, S. Carrideo, P. Tarantino, D. Civitelli, E.V. De Marco, G. Nicoletti, F. Annesi and A. Quattrone, 2003, "Nacp-Rep1 Polymorphism Is Not Involved in Parkinson's Disease: A Case-Control Study in a Population Sample from Southern Italy", *Neuroscience Letters*, Vol. 351, No. 2, pp. 75-78.
- Stefanis, L., 2012, "Alpha-Synuclein in Parkinson's Disease", *Cold Spring Harbor Perspective Medicine*, Vol. 2, No. 2, pp. a009399.
- Subramanian, A., H. Kuehn, J. Gould, P. Tamayo and J.P. Mesirov, 2007, "Gsea-P: A Desktop Application for Gene Set Enrichment Analysis", *Bioinformatics*, Vol. 23, No. 23, pp. 3251-3253.

- Subramanian, A., P. Tamayo, V.K. Mootha, S. Mukherjee, B.L. Ebert, M.A. Gillette, A. Paulovich, S.L. Pomeroy, T.R. Golub, E.S. Lander and J.P. Mesirov, 2005, "Gene Set Enrichment Analysis: A Knowledge-Based Approach for Interpreting Genome-Wide Expression Profiles", *Proceedings of the National Academy of Sciences of the United States of America*, Vol. 102, No. 43, pp. 15545-15550.
- Sudhof, T.C. and J. Rizo, 2011, "Synaptic Vesicle Exocytosis", *Cold Spring Harbour Perspective Biology*, Vol. 3, No. 12.
- Tanaka, H., K. Kannari, T. Maeda, M. Tomiyama, T. Suda and M. Matsunaga, 1999, "Role of Serotonergic Neurons in L-Dopa-Derived Extracellular Dopamine in the Striatum of 6-OHda-Lesioned Rats", *Neuroreport*, Vol. 10, No. 3, pp. 631-634.
- Tarazi, F.I., Z.T. Sahli, M. Wolny and S.A. Mousa, 2014, "Emerging Therapies for Parkinson's Disease: From Bench to Bedside", *Pharmacology & Therapeutics*, Vol. 144, No. 2, pp. 123-133.
- Thayanidhi, N., J.R. Helm, D.C. Nycz, M. Bentley, Y. Liang and J.C. Hay, 2010, "Alpha-Synuclein Delays Endoplasmic Reticulum (Er)-to-Golgi Transport in Mammalian Cells by Antagonizing Er/Golgi Snares", *Molecular Biology of the Cell*, Vol. 21, No. 11, pp. 1850-1863.
- Tofaris, G.K., 2012, "Lysosome-Dependent Pathways as a Unifying Theme in Parkinson's Disease", *Movement Disorders : Official Journal of the Movement Disorder Society*, Vol. 27, No. 11, pp. 1364-1369.
- Tofaris, G.K., P. Garcia Reitböck, T. Humby, S.L. Lambourne, M. O'Connell, B. Ghetti, H. Gossage, P.C. Emson, L.S. Wilkinson, M. Goedert and M.G. Spillantini, 2006, "Pathological Changes in Dopaminergic Nerve Cells of the Substantia Nigra and Olfactory Bulb in Mice Transgenic for Truncated Human Alpha-Synuclein(1-120): Implications for Lewy Body Disorders", *The Journal of Neuroscience : The Official Journal of the Society for Neuroscience*, Vol. 26, No. 15, pp. 3942-3950.

- Tofaris, G.K., H.T. Kim, R. Houriez, J.W. Jung, K.P. Kim and A.L. Goldberg, 2011, "Ubiquitin Ligase Nedd4 Promotes Alpha-Synuclein Degradation by the Endosomal-Lysosomal Pathway", *Proceedings of the National Academy of Sciences of the United States of America*, Vol. 108, No. 41, pp. 17004-17009.
- Trenkwalder, C. and W. Paulus, 2010, "Restless Legs Syndrome: Pathophysiology, Clinical Presentation and Management", *Nature reviews. Neurology*, Vol. 6, No. 6, pp. 337-346.
- Trimbuch, T., J. Xu, D. Flaherty, D.R. Tomchick, J. Rizo and C. Rosenmund, 2014, "Re-Examining How Complexin Inhibits Neurotransmitter Release", *Elife*, Vol. 3, pp. e02391.
- Tsujimura, A., K. Taguchi, Y. Watanabe, H. Tatebe, T. Tokuda, T. Mizuno and M. Tanaka, 2014, "Lysosomal Enzyme Cathepsin B Enhances the Aggregate Forming Activity of Exogenous Alpha-Synuclein Fibrils", *Neurobiology of Disease*, Vol. 73C, pp. 244-253.
- Verstraeten, A., J. Theuns and C. Van Broeckhoven, 2015, "Progress in Unraveling the Genetic Etiology of Parkinson Disease in a Genomic Era", *Trends in Genetics : TIG*, Vol. 31, No. 3, pp. 140-149.
- Walker, D.G., L.F. Lue, C.H. Adler, H.A. Shill, J.N. Caviness, M.N. Sabbagh, H. Akiyama, G.E. Serrano, L.I. Sue and T.G. Beach, 2013, "Changes in Properties of Serine 129 Phosphorylated Alpha-Synuclein with Progression of Lewy-Type Histopathology in Human Brains", *Experimental Neurology*, Vol. 240, pp. 190-204.
- Wang, J., J.G. Hoekstra, C. Zuo, T.J. Cook and J. Zhang, 2013, "Biomarkers of Parkinson's Disease: Current Status and Future Perspectives", *Drug Discovery Today*, Vol. 18, No. 3-4, pp. 155-162.
- Wu, Y., W. Le and J. Jankovic, 2011, "Preclinical Biomarkers of Parkinson Disease", *Archives of Neurology*, Vol. 68, No. 1, pp. 22-30.

- Xia, Y., H.A. Rohan de Silva, B.L. Rosi, L.H. Yamaoka, J.B. Rimmler, M.A. Pericak-Vance, A.D. Roses, X. Chen, E. Masliah, R. DeTeresa, A. Iwai, M. Sundsmo, R.G. Thomas, C.R. Hofstetter, E. Gregory, L.A. Hansen, R. Katzman, L.J. Thal and T. Saitoh, 1996, "Genetic Studies in Alzheimer's Disease with an Nacp/Alpha-Synuclein Polymorphism", *Annual Neurology*, Vol. 40, No. 2, pp. 207-215.
- Xu, J., K.D. Brewer, R. Perez-Castillejos and J. Rizo, 2013, "Subtle Interplay between Synaptotagmin and Complexin Binding to the Snare Complex", *Journal of Molecular Biology*, Vol. 425, No. 18, pp. 3461-3475.
- Xue, M., T.K. Craig, J. Xu, H.T. Chao, J. Rizo and C. Rosenmund, 2010, "Binding of the Complexin N Terminus to the Snare Complex Potentiates Synaptic-Vesicle Fusogenicity", *Nature structural & Molecular Biology*, Vol. 17, No. 5, pp. 568-575.
- Yang, X., P. Cao and T.C. Sudhof, 2013, "Deconstructing Complexin Function in Activating and Clamping Ca²⁺-Triggered Exocytosis by Comparing Knockout and Knockdown Phenotypes", *Proceedings of the National Academy of Sciences of the United States of America*, Vol. 110, No. 51, pp. 20777-20782.